

[CLICK HERE FOR INDEX PAGE](#)

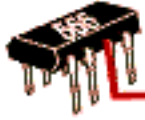

ELECTRONICS INDEX

V. Ryan © 2002

The section is aimed at introducing pupils to basic concepts of electronics. You will find that a range of basic electronics is covered including; component symbols, power sources, diodes, capacitors, transistors, LEDs and many more. Click on the aspect of electronics outlined below to view the information sheets.

THE BASICS

- [1. Components](#)
- [2. Batteries and LEDs](#)
- [3. Switches](#)
- [4. The Diode](#)
- [5. Capacitors](#)
- [6. Test Instruments](#)
- [7. Resistors](#)
- [8. Light Dependent Resistors](#)
- [9. The Preset Resistor](#)
- [10. The Thermistor](#)
- [11. Potential Dividers](#)
- [12. SI Units and OHM's Law](#)
- [13. Relays and Practical Circuits](#)
- [14. The Basics on Transistors](#)
- [15. Transistors - Darlington Pairs](#)
- [16. Transistor Exam Question](#)
- [17. Transistor Breadboard Project](#)
- [18. Transistor Darlington Pair Breadboard Project](#)
- [19. Transistor Formulas and Calculations](#)
- [20. The Thyristor](#)
- [21. Analogue / Digital Systems](#)
- [22. Control Systems](#)

[23. Modular Electronics](#)

[24. Breadboards](#)

THE 555 INTEGRATED CIRCUIT

[1. The 555 Integrated Circuit \(Timer\) - a Simple Explanation](#)

[2. The 555 IC as an ASTABLE Circuit](#)

[3. The 555 IC as a MONOSTABLE Circuit](#)

[4. The MONOSTABLE Circuit in more detail](#)

[5. Astable 555 Breadboard Project](#)

[6. The ASTABLE Circuit in more detail](#)

THE 741 OPERATIONAL AMPLIFIER

[1. The 741 Operational Amplifier - an introduction](#)

[2. Inverting and Non-inverting 741 Amplifiers](#)

[3. The 741 Operational Amplifier as a Comparator](#)

[CLICK HERE FOR INDEX PAGE](#)

COMPONENT SYMBOLS

V. Ryan © 2002

There are a large number of symbols which represent an equally large range of electronic components. It is important that you can recognise the more common components and understand what they actually do. A number of these components are drawn below and it is interesting to note that often there is more than one symbol representing the same type of component. (Check all your information sheets in the [electronics section](#) for more symbols).

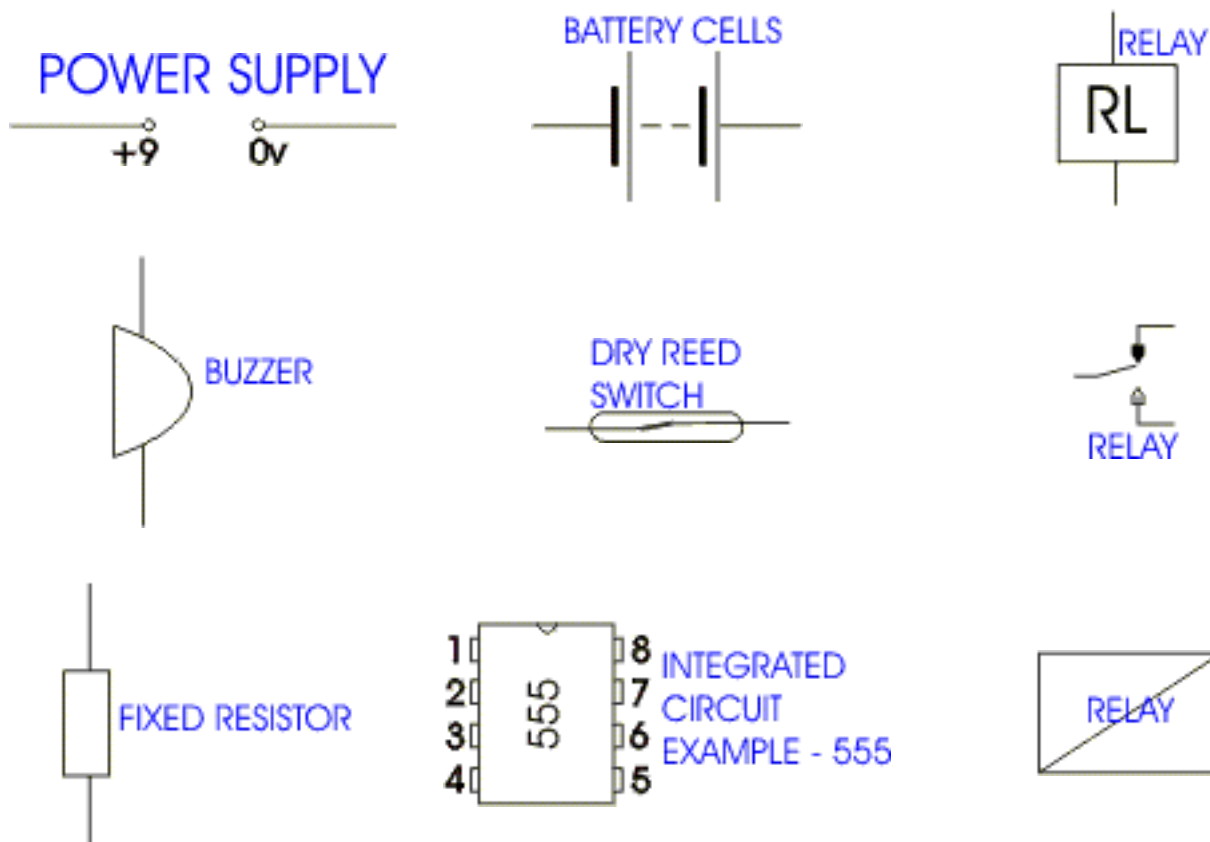

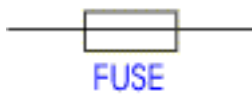
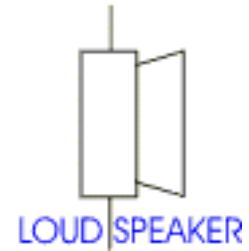
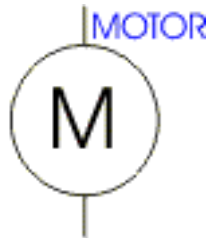
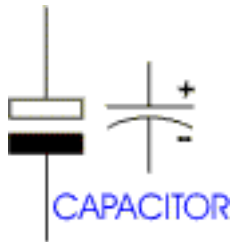
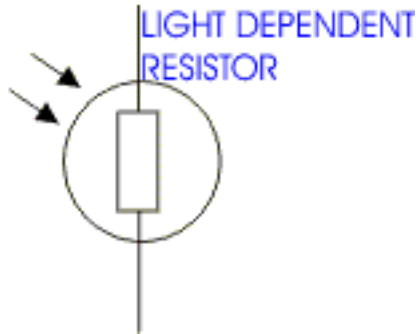
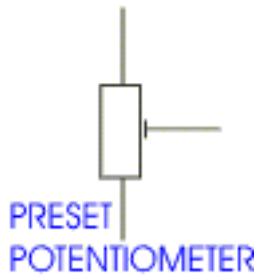
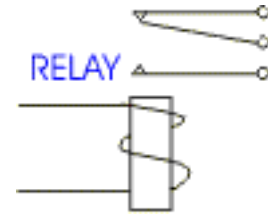
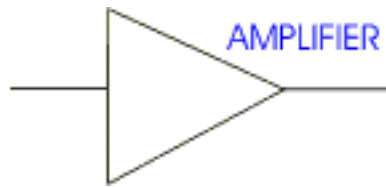
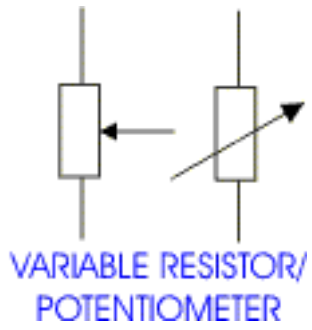

[CLICK HERE FOR INDEX PAGE](#)

V. Ryan © 2002

BATTERIES and LEDs

Many pupils are scared of electronics as they look at the books in the library. These are often very complex as very few have been written for beginners. This can put off people from learning about electronics and circuits. Everywhere we look there are examples of electronics, ranging from a simple radio to a hi-tech digital television. However complex looking an electronic device may be, they are all based on simple components gathered together in circuits.



Batteries come in all shapes and sizes. They store electrical charge and as we all know when they are put into an electronic device such as a portable radio, they provide the power. The usual battery sizes are seen opposite. These are the type used in school projects and range from 1.5 volts to 9 volts. School projects are powered by batteries because they are safe, easily bought and safe.

QUESTION

This shows one of the most simple circuits. When the switch is pressed, the LED (further information below) lights. Resistors are used in circuits because LEDs can be destroyed by voltages over 3 volts. Why do you think the circuit opposite does not have a resistor to protect the LED ?

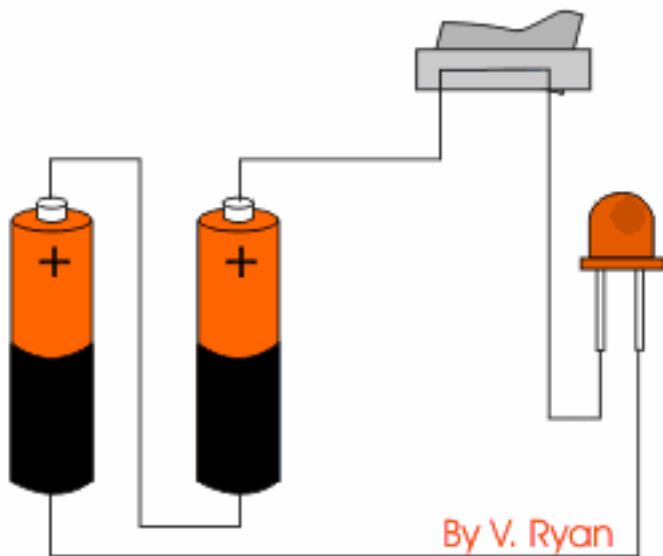

ANSWER

Each battery is 1.5 volts. The two batteries are connected in 'series', they are both linked positive to negative and this gives us a total of 3 volts. Therefore, the LED is safe from damage.

THE LED

Light Emitting Diodes (LED) are very rugged, they last a very long time and they are an optical source. (A LIGHT SOURCE)

LEDs produce red, green, yellow, or orange light. They are used in a range of products.

Can you name any ?

Infrared LEDs are also available although light from this type cannot be seen by the human eye. These are used in security devices.

LEDs are part of the diode family, consequently they must be connected the right way round or current will not pass through.

They are usually protected by a resistor. (See DIODE information sheet).

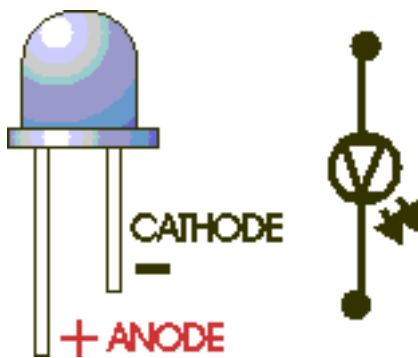

A SELECTION OF THE MOST POPULAR COLOURS



ENLARGED LED - NOTICE THE LONG AND SHORT LEG

[CLICK HERE FOR INDEX PAGE](#)

SWITCHES

V. Ryan © 2002

Some common switches are shown on this information sheet. Basically switches bring contacts together in different ways but they do the same switching job.

Typical Switch Symbols



Normal switch



Push to make



Push to Break

KEY SWITCH



This switch is available in different forms. They provide limited security as a key is required to 'switch' them on and off.

PUSH SWITCH



These can be 'push to make' (push the switch to allow the circuit to work) or 'push to break' (push the switch to turn off the circuit).

ROCKER SWITCH



This switch is common on many electrical devices. For example they are found on computer units for turning them on and off.

TOGGLE SWITCH



These are available in miniature and standard sizes. The advantage of the toggle switch is that they can be extended and operated by a lever.

SLIDE SWITCH



Can be stiff to operate and does not operate smoothly. Available in a range of sizes.

REED / MAGNETIC SWITCH



This is a thin glass tube that contains two thin strips of metal (the reeds). When a magnet is brought close to the glass tube, the reeds move together and make contact and the switch is turned on. The reeds open again when the magnet is removed. Reed switches are common in alarm systems, for example, in door frames. When the door is closed the magnet keeps the switch on. When the door is opened the alarm system senses the broken contact and goes off.

MICRO-SWITCH



Micro-switches can be very small. Usually they include a small arm which when pressed clicks. They are very useful and can be found on many machines - used as safety switches. For example, if the 'lid' of a drilling machine is opened to change the pulley speeds, a micro-switch is released ensuring that all power is turned off. These switches can be very useful in school projects

TILT SWITCH



One of the most common types of tilt switch uses a 'blob' of mercury in a small tube. When the tube is tilted the mercury runs down and forms a bridge across the two contacts turning the switch on. This type of switch is used in warning systems that alert people to an excessive angle of tilt, e.g. for drivers of farm vehicles.

PRESSURE PAD / SWITCH

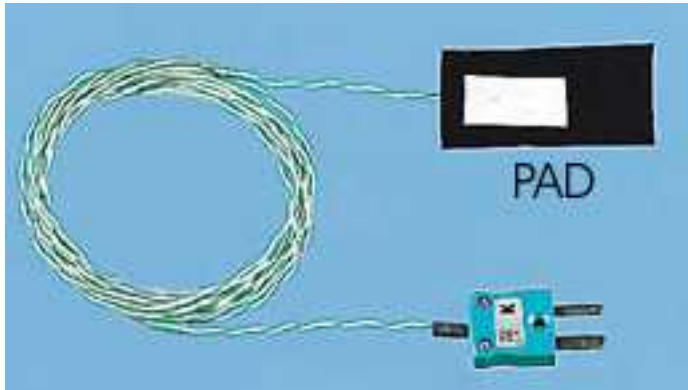

This is a soft flexible switch available in many sizes. It consists of two flexible conductive foil sheets separated by a thin felt, paper or foam layer. If pressure is applied the conductive surfaces touch and the switch is 'on'

[CLICK HERE FOR INDEX PAGE](#)

THE DIODE

V. Ryan © 2002



A diode allows electricity to flow in one direction only and blocks the flow in the opposite direction. They may be regarded as one-way valves and they are used in various circuits, usually as a form of protection. There are different types of diode but their basic functions are the same. These are noted below along with examples of diodes in use.

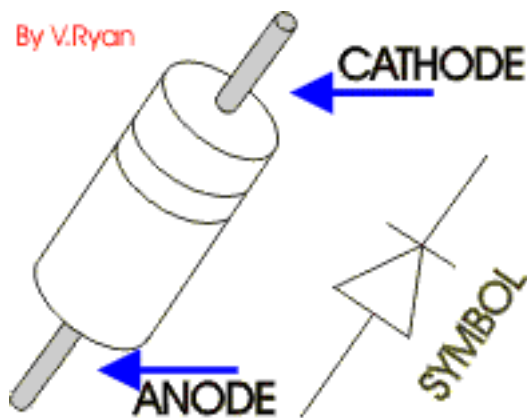

The most common type of diode is a 'silicon diode.' It is enclosed in a glass cylinder with the dark band marking the cathode terminal. This line points towards the positive of a circuit. The opposite terminal is called the anode. Generally, diodes do not conduct until the voltage reaches approximately .6 volts, this is called the 'threshold point'. If the current becomes too high the diode may crack or melt.

TYPICAL USES OF DIODES

REVERSE POLARITY PROTECTOR

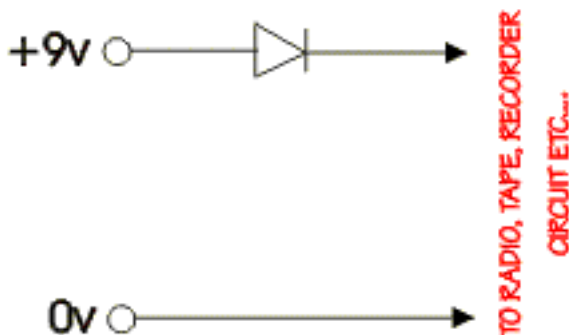

The diode in this circuit protects a radio or a recorder etc... In the event that the battery or power source is connected the wrong way round, the diode does not allow current to flow. Electronic devices can be damaged or even destroyed if the polarity is reversed (positive and negative are connected to the wrong terminals).

TRANSIENT PROTECTOR

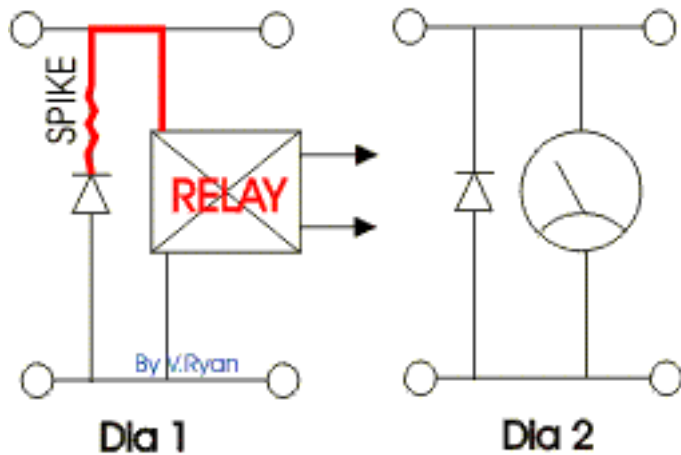

When an 'inductor' device such as a relay is turned off a high voltage can be generated for a short time (Dia 1). This voltage 'spike' can damage the relay and other components. However, the diode does not allow current to pass through it in the wrong direction and short circuits this spike.

The diode can also be used to protect a 'meter' from a reverse current (Dia 2).

ZENER DIODES

Normally a current does not flow through a diode in the reverse direction. The Zener Diode is specifically designed to begin conducting in the opposite direction when the reverse voltage reaches a voltage threshold. Zener diodes are sometimes used as a voltage sensitive switch.

Can you think of any other devices that may benefit from the use of diodes ? What about solenoids ?

[CLICK HERE FOR INDEX PAGE](#)

CAPACITORS

V. Ryan © 2002

Capacitors are components that are used to store an electrical charge and are used in timer circuits. A capacitor may be used with a resistor to produce a timer. Sometimes capacitors are used to smooth a current in a circuit as they can prevent false triggering of other components such as relays.

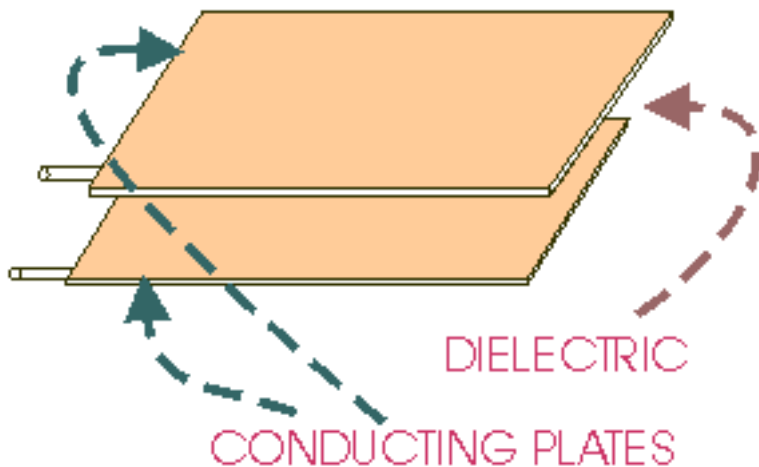

A capacitor is composed of two conductors separated by an insulating material called a DIELECTRIC. The dielectric can be paper, plastic film, ceramic, air or a vacuum. The plates can be aluminium discs, aluminium foil or a thin film of metal applied to opposite sides of a solid dielectric. The CONDUCTOR - DIELECTRIC - CONDUCTOR sandwich can be rolled into a cylinder or left flat

HOW A CAPACITOR WORKS

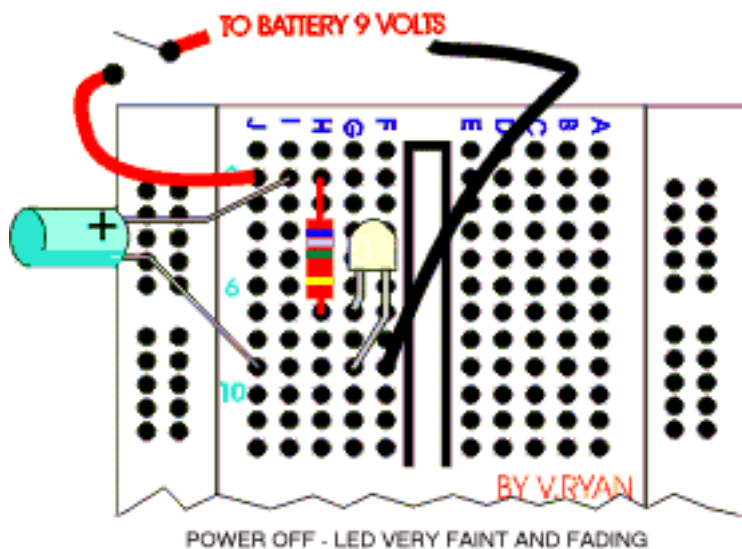

When the circuit is switched on, the light dependent resistor emits light and the capacitor charges up. When the switch is turned off the LED stills emits a light for a few seconds because the electricity stored in the capacitor is slowly discharged. When it has fully discharged it's electricity the LED no longer emits light. If a resistor is introduced to the circuit the capacitor charges up more slowly but also discharges more slowly. What will happen to the light ?

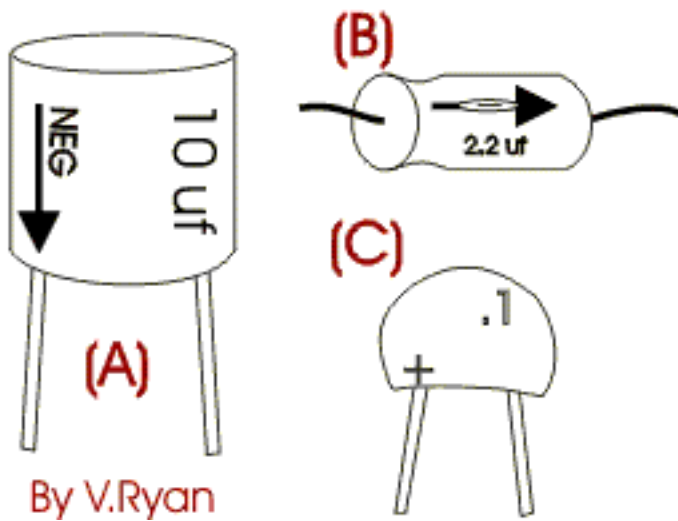

By V.Ryan

Notice the electrolytic capacitors above. They all have two polarised leads, in other words they have a positive and negative leg. This type of capacitor is used with ICs such as the 555 timer chip and it is the capacitors and resistors that determine the timing sequence.



Electrolytic capacitors are 'polarised' which means they have a positive and negative lead and must be positioned in a circuit the right way round (the positive lead must go to the positive side of the circuit).

They also have a much higher capacitance than non-electrolytic capacitors.

Non-electrolytic capacitors usually have a lower capacitance.

They are not *polarised* (do not have a positive and negative lead) and can be placed anyway round in a circuit.

They are normally used to smooth a current in a circuit.

CAPACITANCE - means the value of a capacitor.

Look carefully at the photographs of the two types of capacitors. Can you work out which one is *electrolytic* and which is *non-electrolytic* ?

SYMBOLS

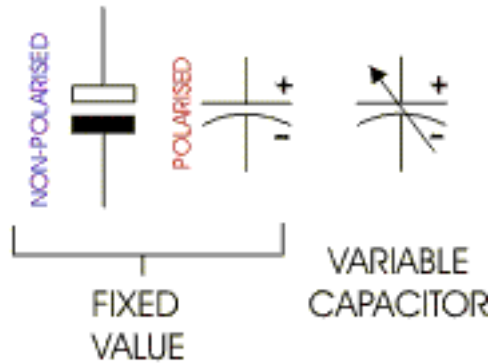

REMEMBER

- there are polarised and non-polarised capacitors.
Look for a positive and negative sign.

The simple circuit below is basically a switch which is connected to a computer. When the switch is pressed the computer detects that the relay is closed and then turns on a motor.

However, there is a problem. When the switch is pressed it only closes the relay for a split second and this is not enough time for the computer program to detect that it has been pressed in the first place. A time delay is the obvious answer and this can be achieved by adding a capacitor in parallel to the switch. If the relay is held closed for 3/4 seconds then the computer program will have time to detect it - A capacitor provides the time delay.

[CLICK HERE FOR EXAMPLES - HOW CAPACITORS CAN BE USED](#)

[CLICK HERE FOR INDEX PAGE](#)



An Analogue Multimeter

TEST INSTRUMENTS

V. Ryan © 2002

Voltage, current and resistance can easily be measured by using a **multimeter**. There are two types, *analogue* and digital. The *multimeter* is the most important electronic test instrument. Two wires are normally used along with the multimeter and they are colour coded - black and red.

DIGITAL METER

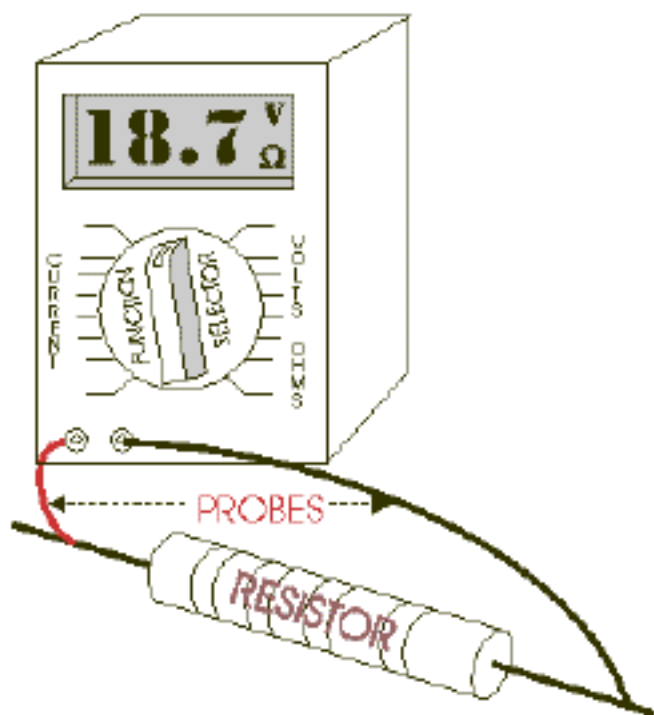

A **DIGITAL** Multimeter is highly accurate and easier to read than an analogue type. It is best used for finding the precise value of a voltage, current or resistance.

An **ANALOGUE** Multimeter is less expensive and less precise than a digital type. Often it will be used for measuring a slowly changing

ANALOGUE METER

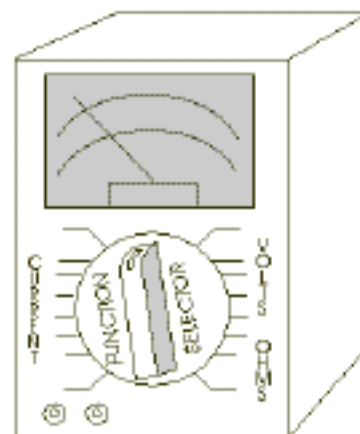

voltage,
current or
resistance.

The probes (seen with the digital metre) are connected to the meter. They can be disconnected and so it is important to ensure that they are attached to the correct sockets when in use. Also, some meters have four possible sockets which means you must follow the manufacturers instructions carefully when attaching the two probes.

Either meter has a variety of settings depending on whether you need to measure resistance, current or voltage. Normally the function selector has a setting for each of these and there is also a setting for the range that you are trying to read.

For example you may need to measure the value of a resistor in ohms when a colour chart is not be available.

In order to do this you would follow these steps:

1. Set the function selector to ohms and to the range where you expect to find a reading. There may be a range for zero to 1K OR 1K and over etc....
2. Ensure that the probes are attached correctly and touch them across the component you are measuring, in this case a resistor.
3. The results can be read on the scale. If there is no reading, try another range setting.

To measure DC voltage follow these steps:

1. Set the function selector to one of the DCV positions.
2. Connect the test probes to the circuit and read the voltage on the scale.



EXAMPLE OF DIGITAL METER



EXAMPLE OF ANALOGUE METER

[CLICK HERE FOR INDEX PAGE](#)

RESISTORS

V. Ryan © 2002

Resistors determine the flow of current in an electrical circuit. Where there is high resistance then the flow of current is small, where the resistance is low the flow of current is large. Resistance, voltage and current are connected in an electrical circuit by **Ohm's Law**.

$$R=V/I \text{ OR } I=V/R \text{ OR } V=R*I$$

Resistors are used for regulating current and they resist the current flow and the extent to which they do this is measured in ohms (Ω). Resistors are found in almost every electronic circuit.

The most common type of resistor consists of a small ceramic (clay) tube covered partially by a conducting carbon film. The composition of the carbon determines how much current can pass through.

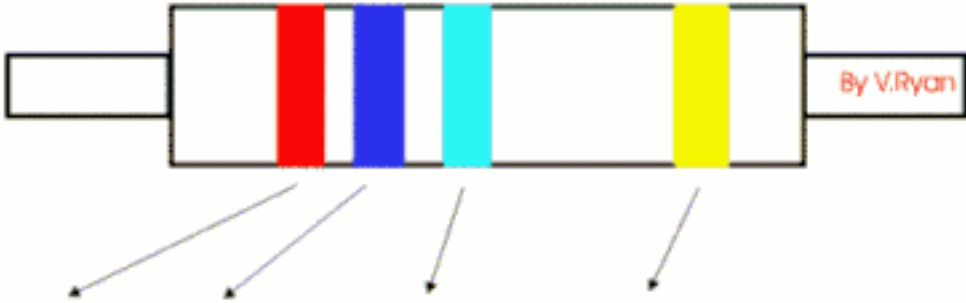

YELLOW 4	VIOLET 7	RED 00	RED +/- 2%	4K7 +/- 2%
GREEN 5	BLUE 6	BLACK NONE	GOLD +/- 5%	56R +/- 5%
BROWN 1	GREY 8	GREEN 00000	SILVER +/-10%	1M8 +/- 10%
ORANGE 3	ORANGE 3	ORANGE 000	NONE +/- 20%	33K +/- 20%

Resistors are too small to have numbers printed on them and so they are marked with a number of coloured bands. Each colour stands for a number. Three colour bands shows the resistors value in ohms and the fourth shows tolerance. Resistors can never be made to a precise value and the tolerance band (the fourth band) tells us, using a percentage, how close the resistor is to its coded value. The resistor on the left is 4700 ohms.

The value of a resistor can be written in a variety of ways. Some examples are given below:

47R means 47 ohms
5R6 means 5.6 ohms
6k8 means 6800 ohms
1M2 means 1 200 000 ohms

A common value is '**K**' which means one thousand ohms. So if a resistor has a value of 7000 ohms it can also be said to have a value of **7K**.

RESISTORS IN SERIES AND IN PARALLEL

Resistors can be connected together in two ways to give different overall values. This is especially useful if you do not have a resistor of the correct value and need to make it up from other available ones.

1. Resistors in SERIES - When resistors are connected in series, their values are added together:

$$R_{\text{total}} = R_1 + R_2$$



For example: $1K + 1K + 3K9 = 5K9$ (total value)

2. Resistors in PARALLEL - When resistors are connected in parallel, their total resistance is given as:

$$\frac{1}{R_{\text{total}}} = \frac{1}{R_1} + \frac{1}{R_2}$$



For example: $1/R_{\text{total}} = 1/1K + 1/1K = 0.5K$ or 500 ohms

$$\text{OR} = \frac{R1 \times R2}{R1 + R2}$$

$$= \frac{1 \times 1}{1 + 1} = \frac{1}{2} = 0.5k$$

[Click here for more resistors in parallel questions](#)

VARIABLE RESISTORS

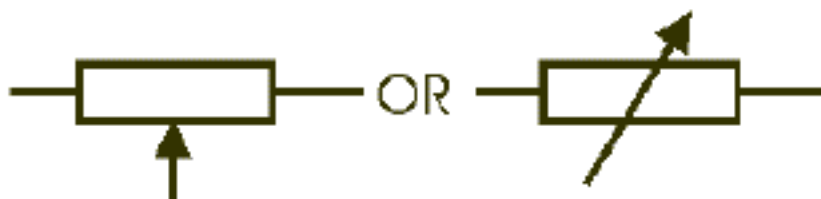

SYMBOL

Variable resistors have adjustable values. Adjustment is normally made by turning a spindle (e.g. the volume control on a radio) or moving a slider.

The **rotary variable resistor** is the cheapest type of variable resistor. A smaller version of this variable resistor is the pre-set resistor. The **pre-set resistor** is the type usually used in small electronic projects (you will probably use this type in school based projects).



PRESET RESISTOR

[CLICK HERE FOR POTENTIAL DIVIDERS SHEET \(RESISTORS CONTINUED\)](#)

[CLICK HERE FOR INDEX PAGE](#)

LIGHT DEPENDENT RESISTORS

V. Ryan © 2002

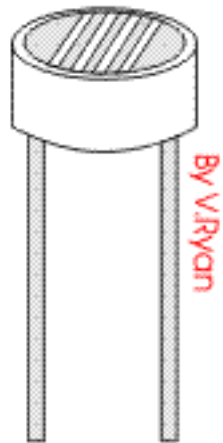

LDR
Light Dependent Resistor

LDRs or Light Dependent Resistors are very useful especially in light/dark sensor circuits. Normally the resistance of an LDR is very high, sometimes as high as 1000 000 ohms, but when they are illuminated with light resistance drops dramatically.

The animation opposite shows that when the torch is turned on, the resistance of the LDR falls, allowing current to pass through it.

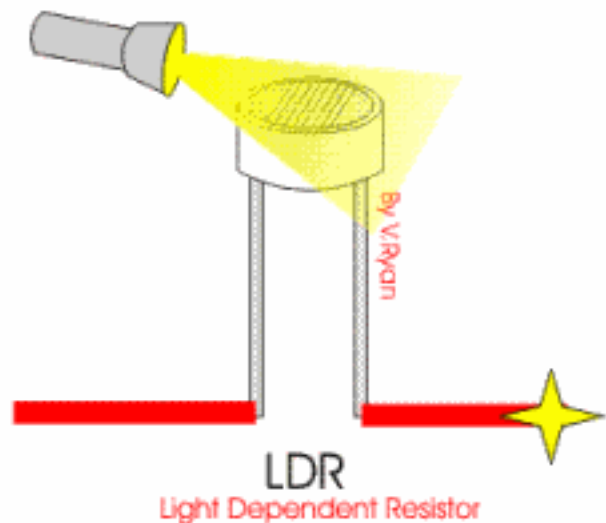

This is an example of a light sensor circuit :

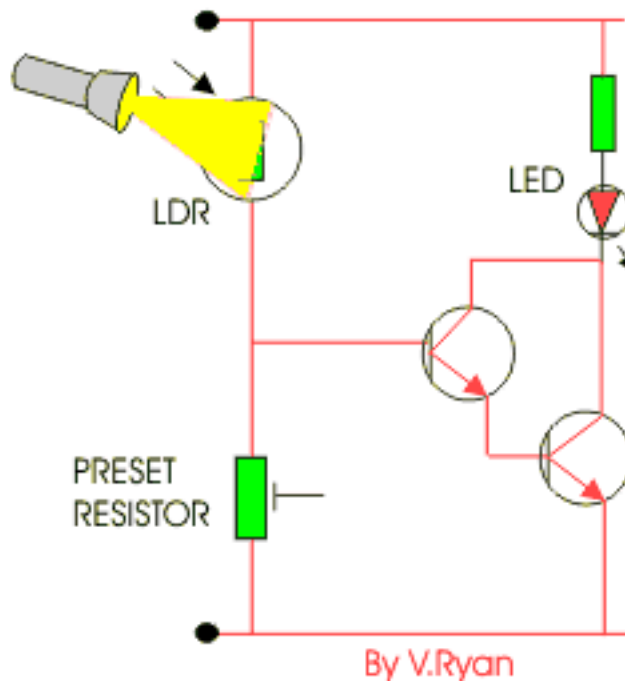

When the light level is low the resistance of the LDR is high. This prevents current from flowing to the base of the transistors. Consequently the LED does not light.

However, when light shines onto the LDR its resistance falls and current flows into the base of the first transistor and then the second transistor. The LED lights.

The preset resistor can be turned up or down to increase or decrease resistance, in this way it can make the circuit more or less sensitive.

1. The circuit above is a light sensor. That means light must shine into the LDR for the circuit to be activated. Draw a circuit composed of the same components that activates when it is DARK (when the LDR is covered). This is a typical examination question.

HINT: Simply swap the preset resistor and the LDR.

2. What is the role of the preset resistor ?

[CLICK HERE FOR ELECTRONICS INDEX PAGE](#)

[CLICK HERE FOR INDEX PAGE](#)

THE PRESET RESISTOR

V. Ryan © 2002

PRESET RESISTOR

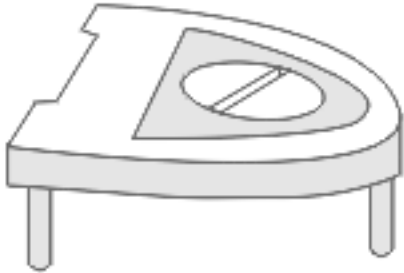

By V.Ryan

Preset resistors are used in circuits when it is necessary to alter the resistance. Dark/light and temperature sensors usually have these components as the preset resistor allows the circuit to be made **more** or **less** sensitive (they can be turned up or down - reducing or increasing resistance).

A small screwdriver can be used to turn the centre part of the preset resistor, altering the value of the resistance.

The range of resistance varies, for example:

0 to 100 ohms

0 to 1M ohms

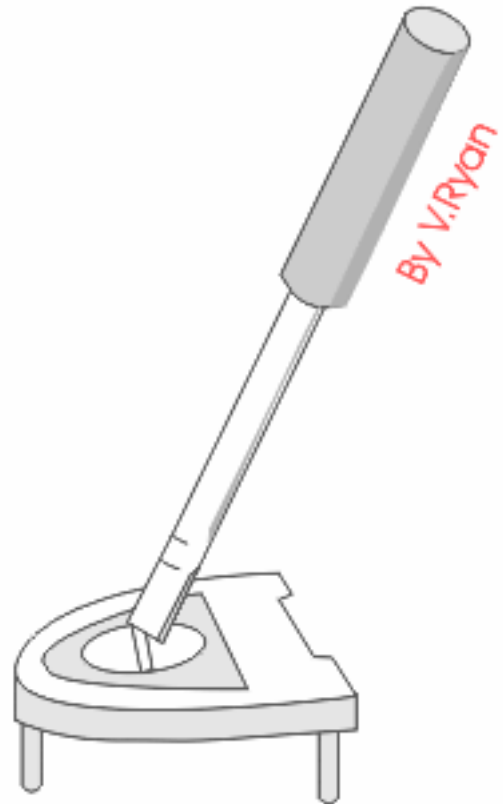

The two circuits below are sensor circuits. The one on the left is a temperature sensor and the one on the right is a light sensitive circuit. Increasing the value of the preset resistor by turning the centre with a small screwdriver makes the circuit less sensitive. For instance, the temperature sensor would require a higher temperature and the light sensitive circuit would need more intense light before they activated.

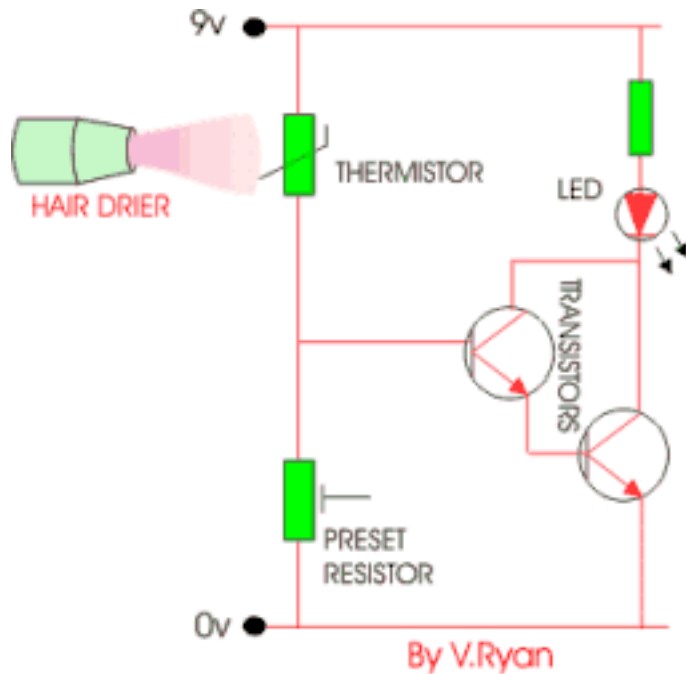

TEMPERATURE SENSOR

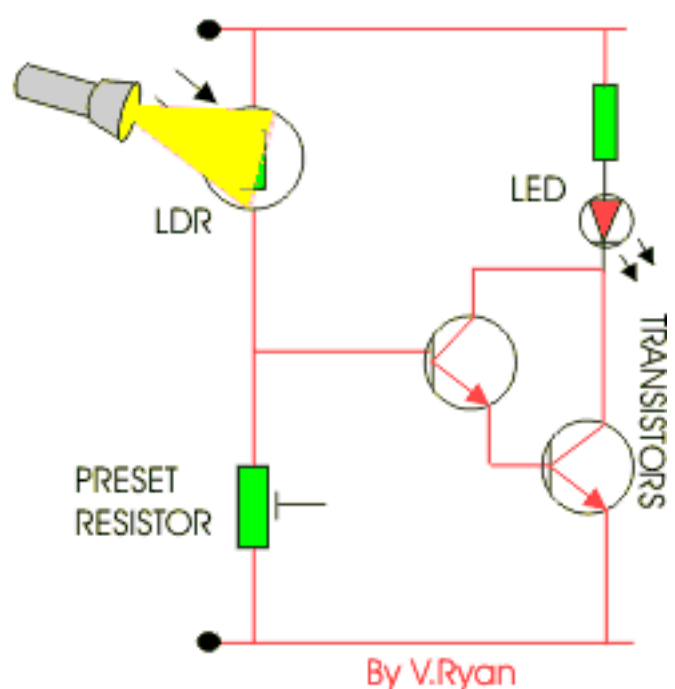

LIGHT SENSOR

[CLICK HERE FOR ELECTRONICS INDEX PAGE](#)

[CLICK HERE FOR INDEX PAGE](#)

THE THERMISTOR

V. Ryan © 2002

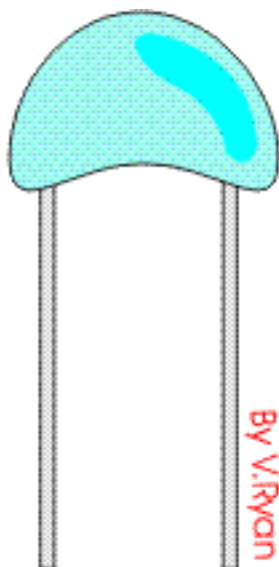

An example of a thermistor is seen to the left. They are made up of a mixture of sulphides or oxides or sometimes metals such as copper, iron or cobalt. They tend to be formed into a disc or a bead sealed with plastic or glass.

They have great resistance at low temperatures but when they warm up their resistance decreases rapidly. Current can then flow through them. This makes them ideal as one of the components for a temperature sensor.

Build the simple thermistor circuit below. When the thermistor is cool or cold the LED should not light because of the high resistance.

However, warm up the thermistor by blowing warm air from a hair drier across it. This should warm it sufficiently that in a few seconds the resistance will drop and the LED will light.

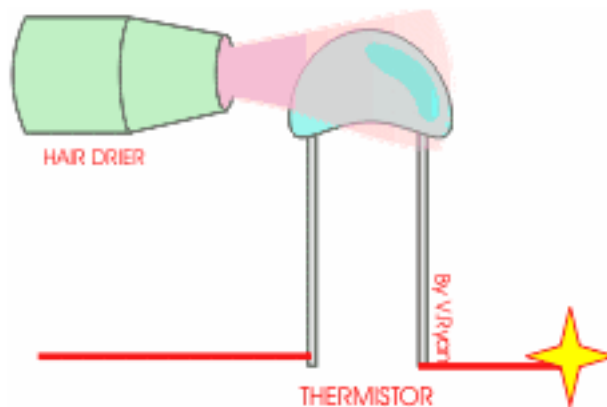

WHEN THE THERMISTOR IS COLD RESISTANCE IS HIGH AND CURRENT CANNOT PASS THROUGH. WHEN WARMED, RESISTANCE FALLS AND CURRENT PASSES THROUGH.

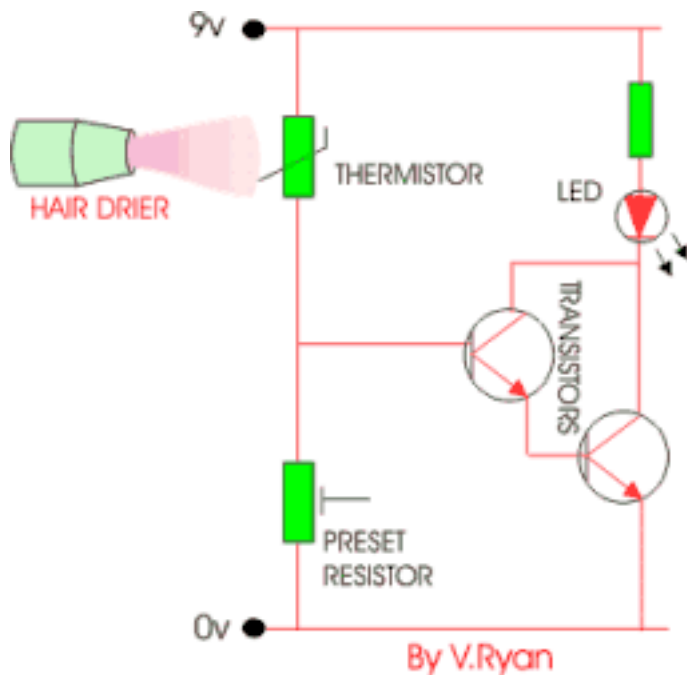

Circuit explanation in detail:

When the thermistor is warmed up by the hair drier its resistance drops, this will take a few seconds. As its resistance drops current begins to flow from positive 9 volts to negative 0 volts. Current flows into the base of the transistors allowing the LED to light.

The preset resistor can be turned up or down to increase or decrease resistance, in this way it can make the circuit more or less sensitive.

1. Explain how this circuit could be used in the home.
2. What is the role of the preset resistor ?

[CLICK HERE FOR INDEX PAGE](#)

POTENTIAL DIVIDERS

V. Ryan © 2002

What are they - they can be used to split the voltage of a circuit. They are widely used in electronic circuits for setting and adjusting voltages - e.g. in radios, games and toys. You may find that you need a supply of 6 volts and you have a 9 volt battery, your only option may be to make a potential divider.

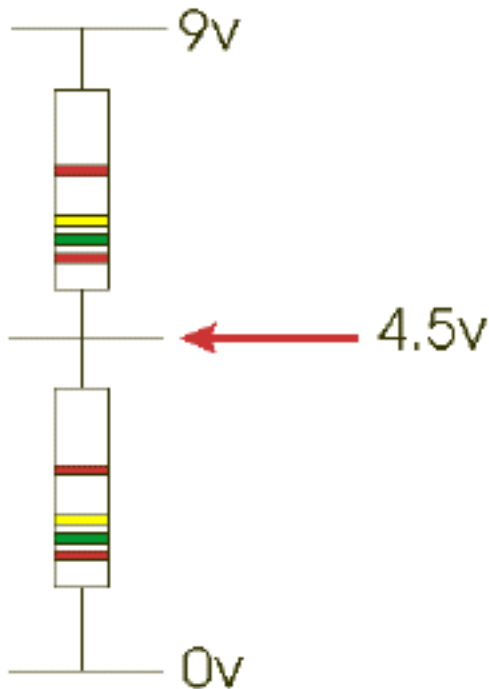

When two resistors of equal value (e.g. 1K) are connected across a supply, current will flow through them. If a meter is placed across the supply shown in the diagram it will register 9v. If the meter is then placed between the 0v and the middle of the two resistors it will read 4.5v. The battery voltage has been divided in half.

If the resistor values are changed to 2K and 1K the voltage will be 6v. The voltage at the centre is determined by the ratio of the two resistor values and is given by the formula:

$$V = \text{supply voltage} \times \frac{R_2}{R_1 + R_2}$$

$$V = 9\text{v} \times \frac{2000}{1000 + 2000}$$

$$V = 9\text{v} \times (2000/3000 \text{ ohms})$$

$$V = 9\text{v} \times 0.6666666 \text{ ohms}$$

$$V = 6\text{v}$$



An alternative way to work out the answer is to:

$$1\text{K} + 2\text{K} = 3\text{K}$$

1. Add both resistors together.

$$9\text{v}/3\text{k} \text{ (is the same as } 9/3) = 3$$

2. Divide the voltage by the sum of both resistors.

3. Take the largest resistor and multiply it by the answer found in stage two.

$$2\text{k} \times 3 = 6\text{v}$$

[CLICK HERE FOR MORE POTENTIAL DIVIDER QUESTIONS](#)

[CLICK HERE FOR INDEX PAGE](#)

SI UNITS and OHM's LAW

V. Ryan © 2002

SI UNITS

The system of units used in Technology and Science is the Systeme Internationale d'unités (International system of units). Usually abbreviated to SI units and is based on the metric system. This was introduced in 1960 and is now adopted by the majority of countries as the official system of measurement. The basic units in the **SI** system are listed in the table to the right with their symbols.

PREFIX	NAME	MEANING
T	tera	multiply by 1 000 000 000 000 (i.e. X 10 ¹²)
G	giga	multiply by 1 000 000 000 (i.e. X 10 ⁹)
M	mega	multiply by 1 000 000 (i.e. X 10 ⁶)
k	kilo	multiply by 1 000 (i.e. X 10 ³)
m	milli	divide by 1000 (i.e. X 10 ⁻³)
μ	micro	divide by 1 000 000 (i.e. X 10 ⁻⁶)
n	nano	divide by 1 000 000 000 (i.e. X10 ⁻⁹)
p	pico	divide by 1 000 000 000 000 (i.e. X 10 ⁻¹²)

Ohm's Law

Provides us with a very important formula for working out current, resistance and voltage (Potential Difference). In order to use this formula properly you must understand SI Units.

$$\text{Voltage} = V \quad \text{Resistance} = R \quad \text{Current} = I$$

From OHM's Law :



Problem 1. If the current through a resistor is 0.8A and the voltage is 20v - what is the resistance ?

$$\text{resistance } R = \frac{V}{I} = \frac{20}{0.8} = \frac{200}{8} = 25\Omega$$

$$\text{Resistance } R = 2\text{k}\Omega = 2 \times 10^3 = 2000 \Omega.$$

$$\text{Current } I = 10\text{mA} = 10 \times 10^{-3} \text{ A or } 0.01 \text{ A.}$$

From Ohm's law, potential difference,

$$V = IR = (0.01)(2000) = 20\text{V}$$

Problem 3. A coil has a current of 50 mA flowing through it when the voltage is 12 V. What is the resistance of the coil?

$$\text{Resistance } R = \frac{V}{I} = \frac{12}{50 \times 10^{-3}} = \frac{12}{.05} = 240\Omega$$

Have a go at answering the following questions:

Problem 4. A 100 V battery is connected across a resistor and causes a current of 5mA to flow. Determine the resistance of the resistor. If the voltage is reduced to 25 V, what will be the new value of the current flowing?

Problem 5. What is the resistance of a coil which draws a current of (a) 50 mA and (b) 200mA from a 120 V supply.

What is an INSULATOR ?

An insulator is a material that does not allow current to flow through it. Materials such as rubber and plastic are good insulators and this is why they are used in the electrical industry to insulate parts.

Consider electric drills. Why do they have a plastic case ? The plastic insulates the person using the drill from all the electrical parts so that they are protected from electrocution.

[CLICK HERE FOR INDEX PAGE](#)

THE RELAY

V. Ryan © 2002

A relay is an electromagnetic switch. In other words it is activated when a current is applied to it. Normally a relay is used in a circuit as a type of switch (as you will see below). There are different types of relays and they operate at different voltages. When you build your circuit you need to consider the voltage that will trigger it.

RELAY SYMBOLS

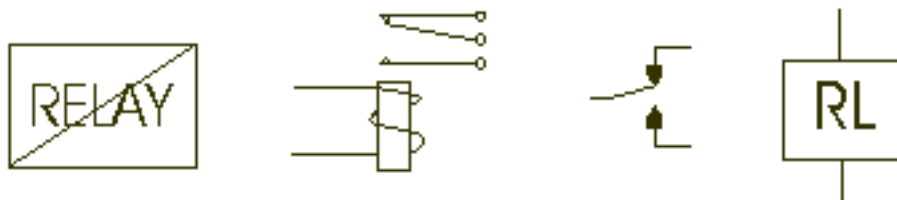

HOW A RELAY LOOKS ON THE OUTSIDE

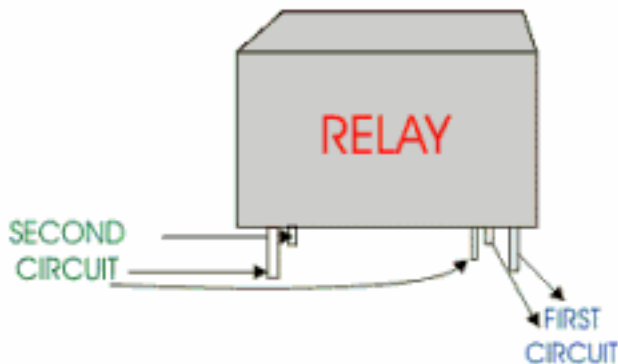

By V.Ryan

HOW A RELAY LOOKS ON THE INSIDE

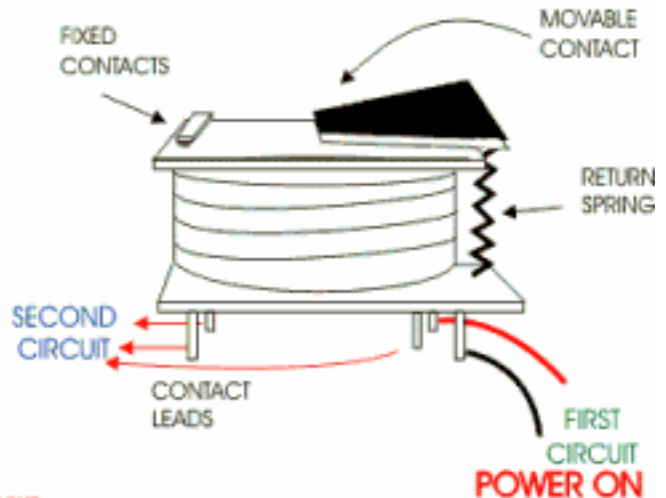

The main part of a relay is the coil at the centre. A small current flowing through the coil in the relay creates a magnetic field that pulls one switch contact against or away from another. Putting it simply, when current is applied to the contacts at one side of the relay the coil allows the contacts at the other side to work.

Usually relays are used to turn on a second circuit. The first circuit activates the relay which then 'turns on' the second circuit.

EXAMPLE CIRCUIT

This simple circuit activates the relay only when the LDR is dark (covered). This could be used as part of an automatic animal feeder. For instance, if the animal was fed at night the circuit above would activate the relay. A second circuit, connected to the other side of the relay releases food into a dish.

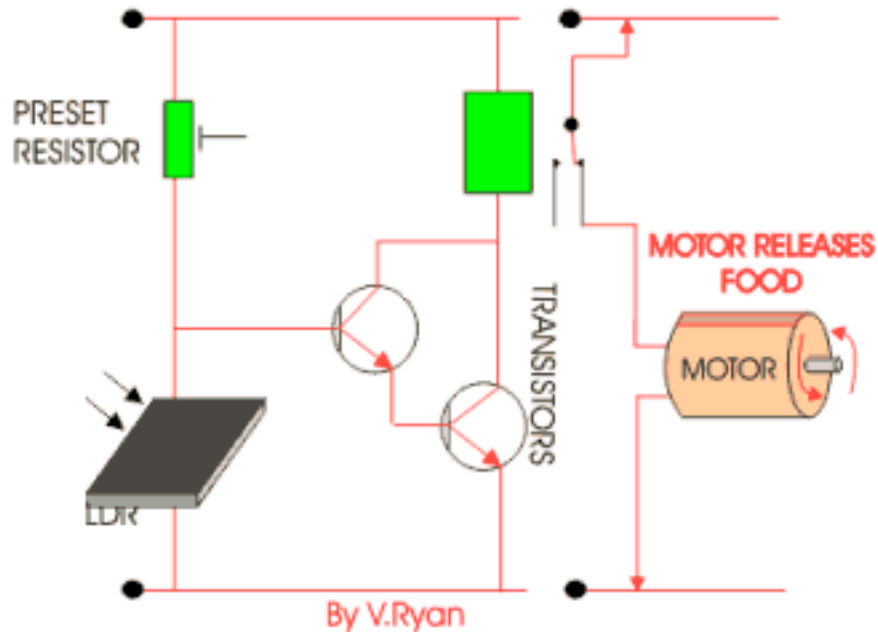

[CLICK HERE FOR PRACTICAL EXAMPLES OF RELAYS](#)

[CLICK HERE FOR ELECTRONICS INDEX PAGE](#)

[CLICK HERE FOR INDEX PAGE](#)

TRANSISTORS

V. Ryan © 2002

Transistors can be regarded as a type of switch, as can many electronic components. They are used in a variety of circuits and you will find that it is rare that a circuit built in a school Technology Department does not contain at least one transistor. They are central to electronics and there are two main types; NPN and PNP. Most circuits tend to use NPN. There are hundreds of transistors which work at different voltages but all of them fall into these two categories.

TWO EXAMPLES OF DIFFERENT SHAPES OF TRANSISTOR

Transistors are manufactured in different shapes but they have three leads (legs).

The *BASE* - which is the lead responsible for activating the transistor.

The *COLLECTOR* - which is the positive lead.

The *EMITTER* - which is the negative lead.

The diagram below shows the symbol of an *NPN* transistor. They are not always set out as shown in the diagrams to the left and right, although the 'tab' on the type shown to the left is usually next to the 'emitter'.

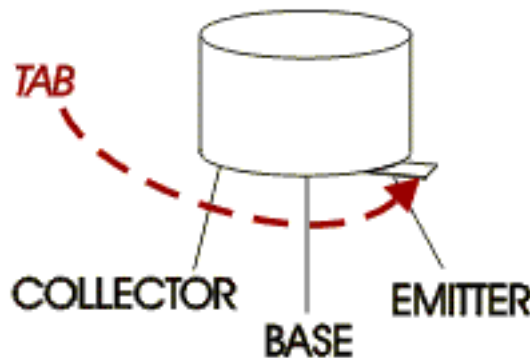
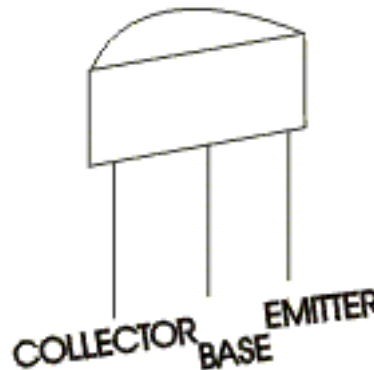

The leads on a transistor may not always be in this arrangement. When buying a transistor, directions will normally state clearly which lead is the *BASE*, *EMITTER* or *COLLECTOR*.

SIMPLE USE OF A TRANSISTOR

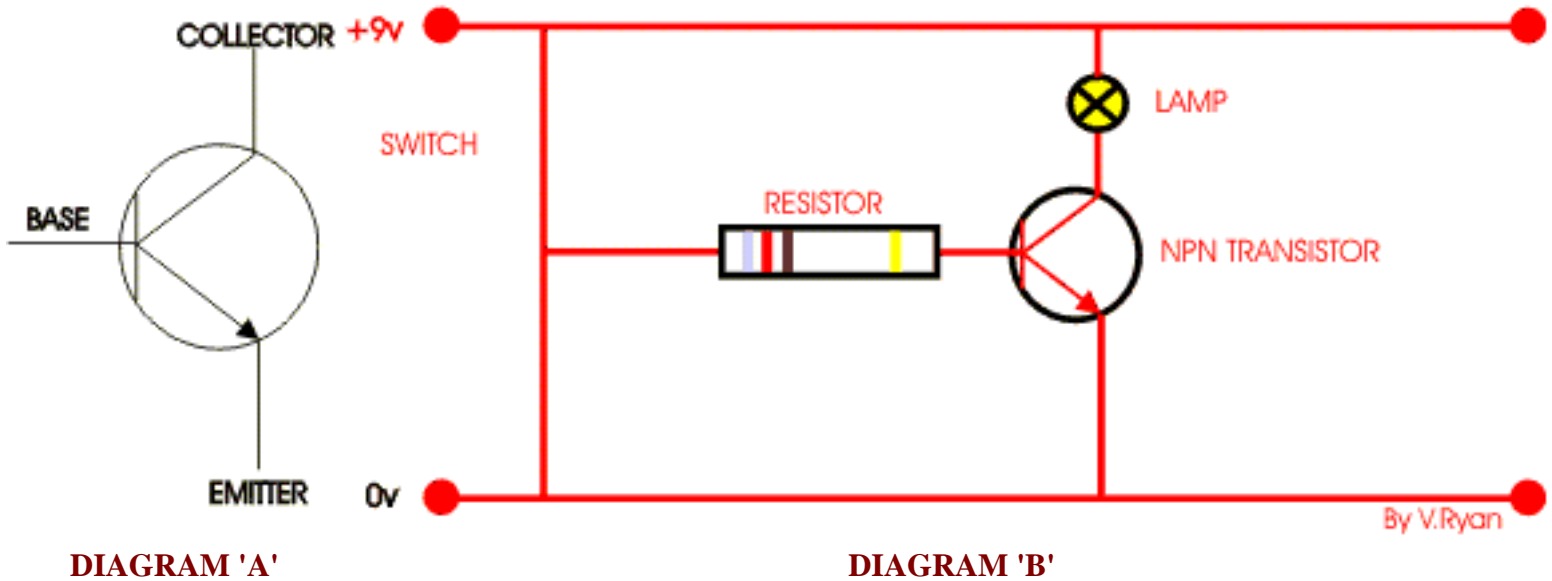

DIAGRAM 'A'

DIAGRAM 'B'

Diagram 'A' shows an NPN transistor which is often used as a type of switch. A small current or voltage at the *base* allows a larger voltage to flow through the other two leads (from the *collector* to the *emitter*).

The circuit shown in **diagram B** is based on an NPN transistor. When the switch is pressed a current passes through the resistor into the *base* of the transistor. The transistor then allows current to flow from the +9 volts to the 0vs, and the lamp comes on.

The transistor has to receive a voltage at its '*base*' and until this happens the lamp does not light.

The resistor is present to protect the transistor as they can be damaged easily by too high a voltage / current. Transistors are an essential component in many circuits and are sometimes used to amplify a signal.

[CLICK HERE FOR MORE ON TRANSISTORS \(DARLINGTON PAIRS\)](#)

[CLICK HERE FOR INDEX PAGE](#)

THE DARLINGTON PAIR

V. Ryan © 2002

Transistors are an essential component in a sensor circuit. Usually transistors are arranged as a pair, known as a '**DARLINGTON PAIR**'. It is very important that you can identify this arrangement of transistors and state clearly why they are used.

A darlington pair is used to amplify weak signals so that they can be clearly detected by another circuit or a computer/microprocessor.

The circuit opposite is a 'Darlington Pair' driver. The first transistor's emitter feeds into the second transistor's base and as a result the input signal is amplified by the time it reaches the output.

The important point to remember is that the Darlington Pair is made up of two transistors and when they are arranged as shown in the circuit they are used to amplify weak signals.

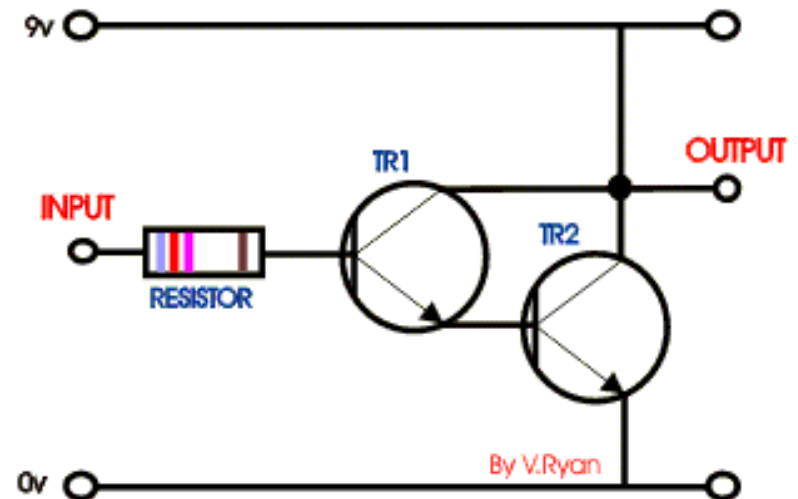
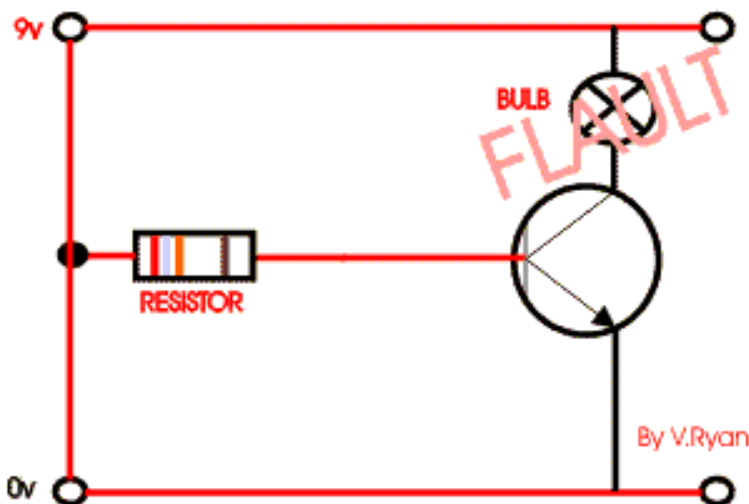

The circuit to the right shows a single transistor. When the switch is pressed current flows from the 9v to the 0v and also to the base of the transistor. This allows the transistor to switch and in turn, current / voltage flows through the bulb, which lights.

However, there is a potential problem with this circuit. The signal / current at the base of the transistor may be too weak to switch the transistor and allow the bulb to light or it may flicker on and off.

A possible solution is seen to the right. A second transistor is added to the circuit, the circuit is now likely to work as the original signal / current is amplified.

The amount by which the weak signal is amplified is called the 'GAIN'.

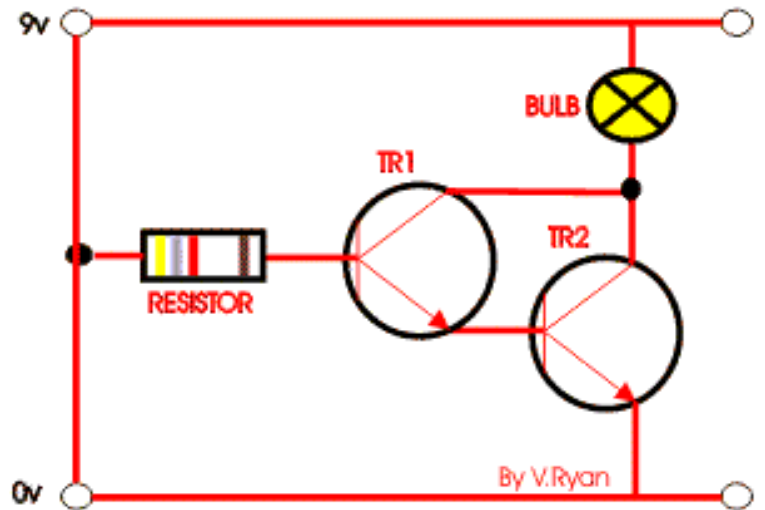

[CLICK HERE FOR EXAMINATION QUESTION](#)

[CLICK HERE FOR INDEX PAGE](#)

TRANSISTOR EXAM QUESTION

V. Ryan © 2002

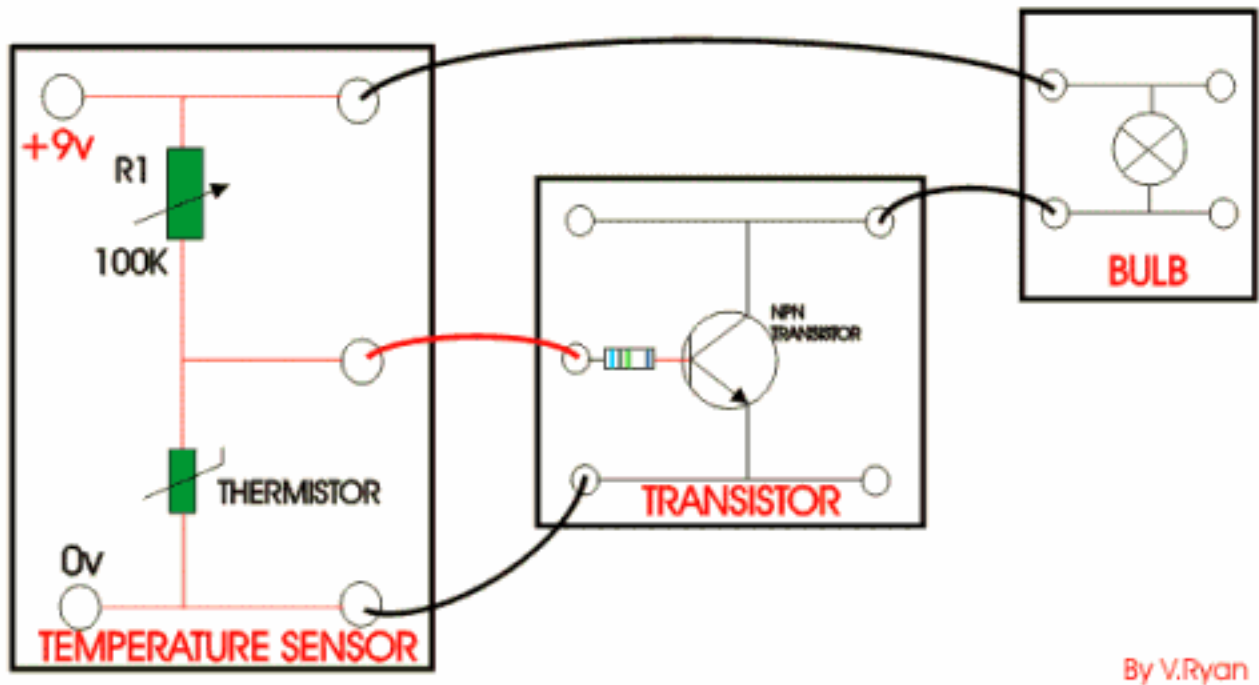

By V.Ryan

Above is a temperature sensor made up of different circuits called modules. When the thermistor is warmed its resistance falls, allowing current to flow from positive 9 volts to 0 volts. In turn, current flows from the temperature module to the transistor module triggering the transistor. The bulb module then lights.

However, there is a problem - the bulb flickers on and off. Redesign the transistor module to ensure that the bulb is constantly alight.

Explain how the three modules work together.

THE ANSWER IS SEEN BELOW:

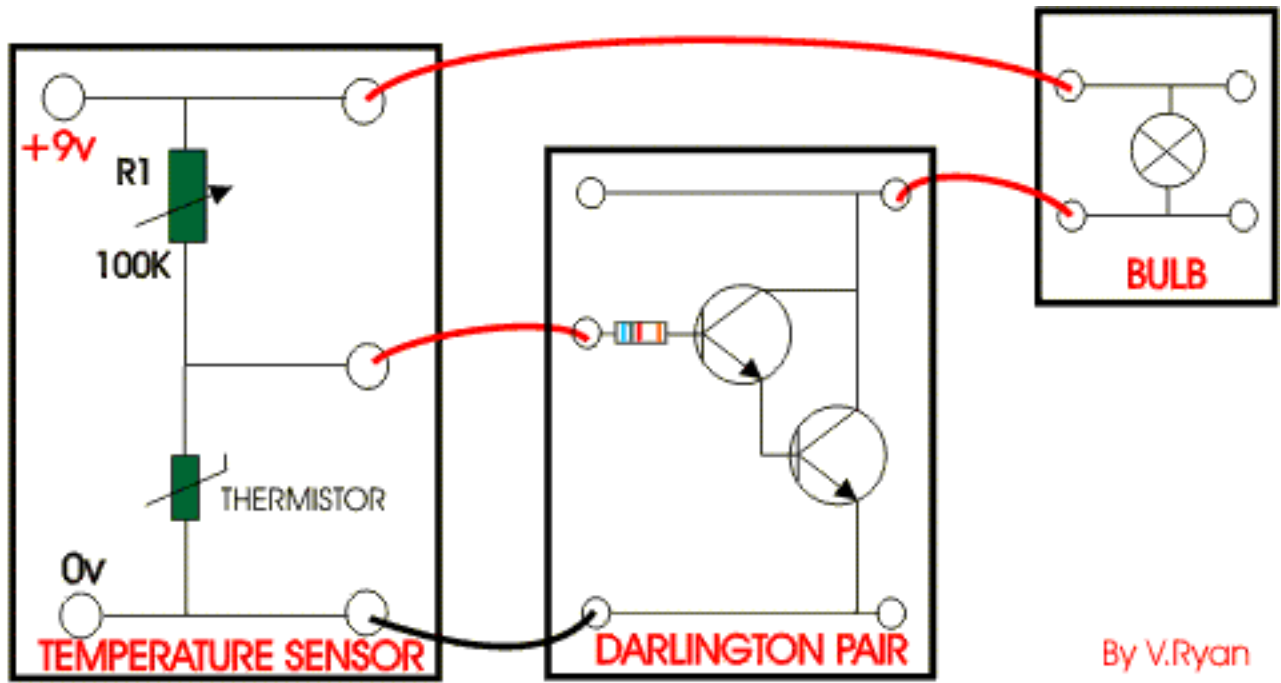

[CLICK HERE FOR INDEX PAGE](#)

TRANSISTOR BREADBOARD PROJECT

V. Ryan © 2002

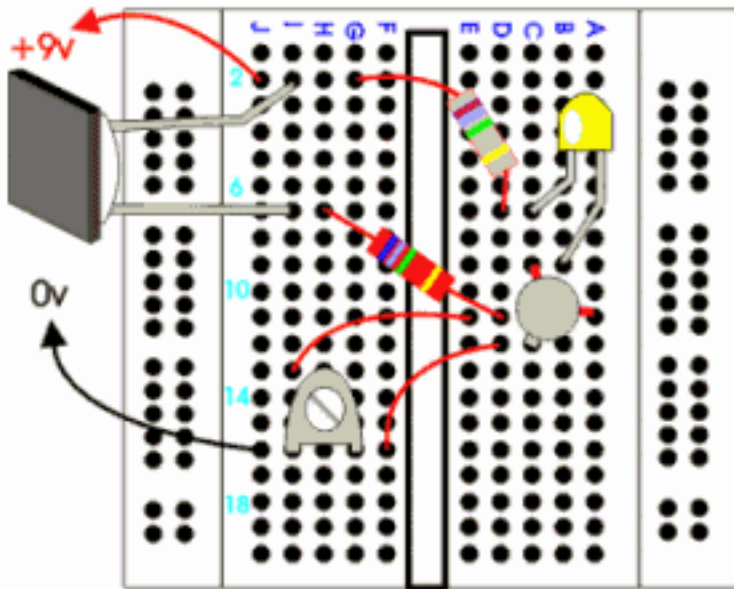

Components:

680 ohm resistor to protect the LED.
 1K resistor from LDR to the base of the NPN transistor.
 One BFY50 npn transistor (try any alternative).
 One 10K preset resistor.
 One LDR.

PIN LAYOUT OF NPN TRANSISTOR



1. Build the breadboard circuit shown above. This is a dark sensor and relies on several components, in particular the transistor. When the LDR is covered the LED will light, although there may be a need to alter the setting of the preset resistor.

How it works:

When light shines into the LDR its resistance is high and consequently current cannot flow from positive 9 volts to negative 0 volts. If the LDR is completely covered its resistance falls dramatically. Current then flows into the base of the transistor switching it on. Consequently current can flow through the collector and emitter - therefore, the LED lights.

2. Try building a light sensor, that is a circuit in which the LED lights if light shines into the LDR. HINT; try swapping round the LDR and the preset resistor.

3. Try building a similar circuit but this time add an arrangement of transistors called a [Darlington Pair](#). Do you find any difference in the operation of the circuit ?
4. Try building a similar dark sensor but this time with a relay rather than an LED.

[CLICK HERE FOR ELECTRONICS INDEX](#)

[CLICK HERE FOR INDEX PAGE](#)

TRANSISTOR BREADBOARD PROJECT

V. Ryan © 2002

DARLINGTON PAIR PROJECT

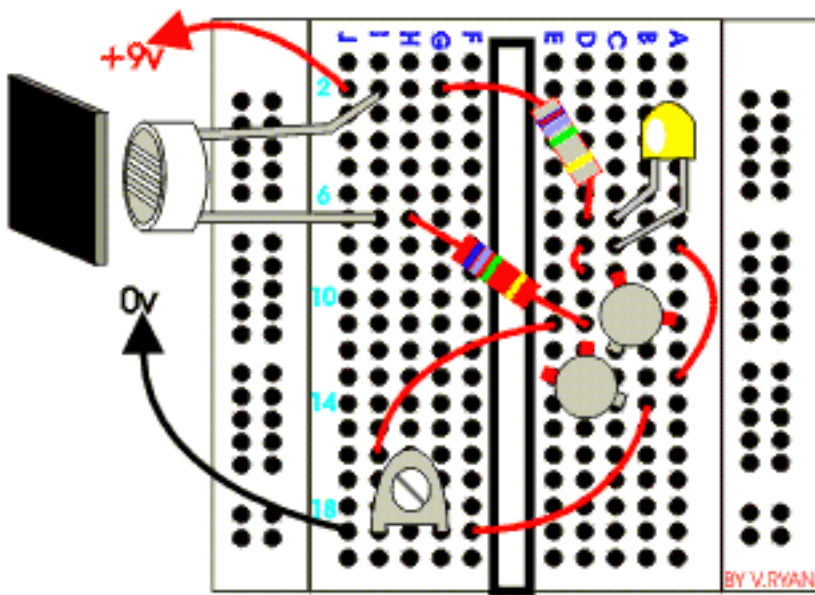

Components:

- 680 ohm resistor to protect the LED.
- 1K resistor from LDR to the base of the NPN transistor.
- TWO BFY50 npn transistor (try any alternative).
- One 10K preset resistor.
- One LDR.
- Black and red wire.

LAYOUT OF FIRST TRANSISTOR:



LAYOUT OF SECOND TRANSISTOR

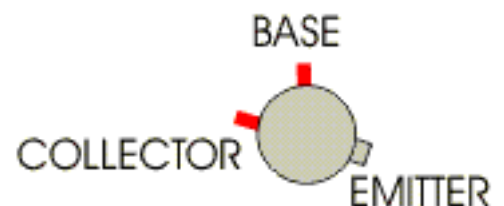

The legs/pins on the second transistor have been twisted slightly to allow them to be pushed into the breadboard in the correct positions:

When a single transistor is used in the circuit, [as seen earlier](#), the LDR has to be completely covered before the LED lights. This is because the circuit lacks sensitivity as the current into the base of the transistor is quite weak. A darlington pair is needed to amplify the current and this is achieved by the first transistors emitter feeding into the base of the second transistor. The current is amplified to a greater level and the LDR has only to be covered partially before the LED lights.

[CLICK HERE FOR ELECTRONICS INDEX](#)

[CLICK HERE FOR INDEX PAGE](#)

TRANSISTOR FORMULAS

V. Ryan © 2002

Transistors are used to amplify current and so in an examination you could be asked to find the BASE current or COLLECTOR current or the GAIN. The GAIN is simply the amount of amplification. The formulas and example questions are set out below:

A simple way of remembering the formula is seen in the diagram opposite OR you can learn each of the formulas below.

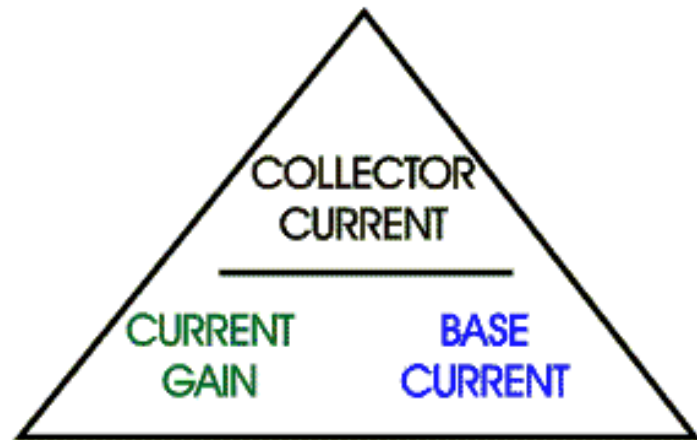

$$\begin{array}{l} \text{CURRENT GAIN} = \frac{\text{COLLECTOR CURRENT}}{\text{BASE CURRENT}} \\ \text{BASE CURRENT} = \frac{\text{COLLECTOR CURRENT}}{\text{CURRENT GAIN}} \\ \text{COLLECTOR CURRENT} = \text{BASE CURRENT} \times \text{CURRENT GAIN} \end{array}$$

Another very important point to remember is that collector current is always greater than base current, sometimes by many times.

TRY THE FOLLOWING QUESTIONS:

1. If the collector current of a transistor is 0.12 amps and the gain is 40, what is the base current?

$$\text{BASE CURRENT} = \frac{\text{COLLECTOR CURRENT}}{\text{CURRENT GAIN}} = \frac{0.12}{40} = 0.003 \text{ amps or 3 milli-amps}$$

2. If the collector current of a transistor is 0.4 amps and the base current is 0.002 amps, what is the current gain?

$$\text{CURRENT GAIN} = \frac{\text{COLLECTOR CURRENT}}{\text{BASE CURRENT}} = \frac{0.4}{0.002} = 200$$

3. If the collector current of a transistor is 0.5 amps and the gain is 100, what is the base current?

$$\text{BASE CURRENT} = \frac{\text{COLLECTOR CURRENT}}{\text{CURRENT GAIN}} = \frac{0.5}{100} = 0.005 \text{ amps or } 5 \text{ milli-amps}$$

[CLICK HERE TO RETURN TO ELECTRONICS INDEX](#)

[CLICK HERE FOR INDEX PAGE](#)

THE THYRISTOR

V. Ryan © 2002

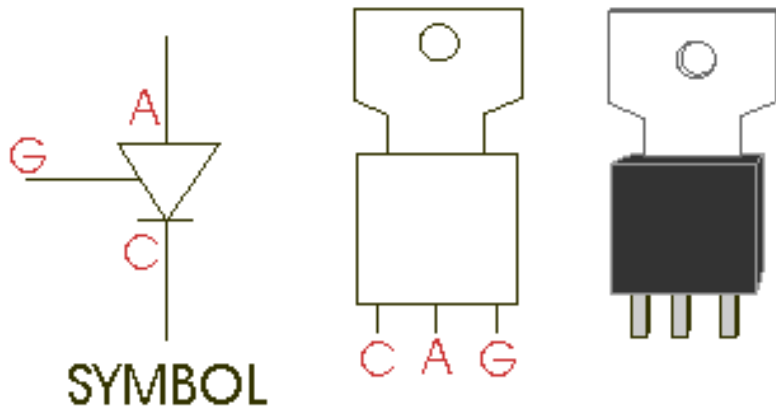

A Thyristor (silicon controlled rectifier or SCR) is a little like a transistor. When a small current flows into the **GATE (G)**, this allows a larger current to flow from the **ANODE (A)** to the **CATHODE (C)**. Even when the current into the gate stops the thyristor continues to allow current to flow from anode to cathode. It latches on.

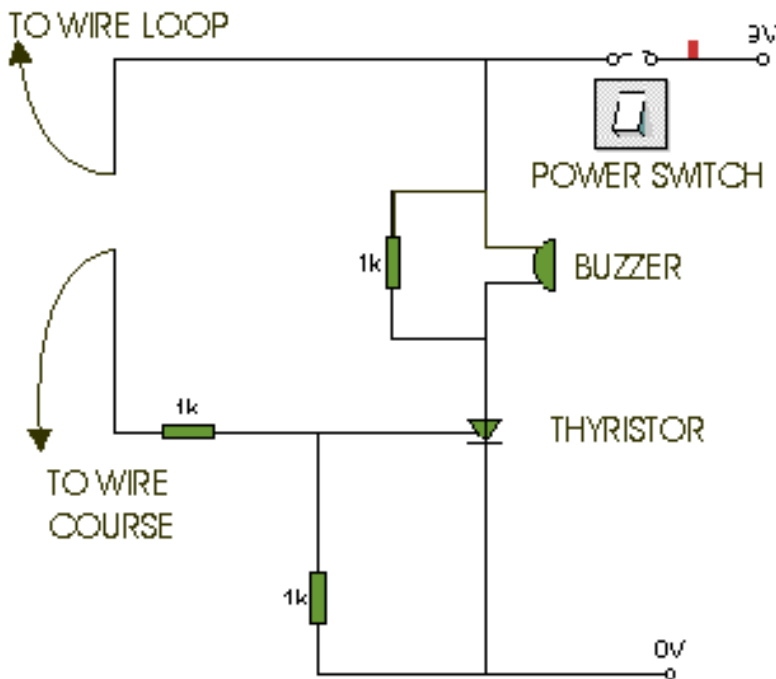

The circuit opposite represents a steady hand game which consists of a wire loop that has to be moved around a wire course without touching it. If the wire course is touched by the loop a buzzer sounds until all power is switched off or a reset button is pressed.

The buzzer will continue to sound after the loop has touched the wire course. This is due to the thyristor which once activated cannot be deactivated until all power is turned off.

This type of circuit is also known as a '*latching circuit*'

ALARM CIRCUIT

The circuit below is an alarm circuit and it incorporates a thyristor. When the house holder leaves he/she turns on the master power switch and the exit switch. If an intruder steps on the pressure pad the alarm sounds and 'latches' on (stays on) because of the thyristor.

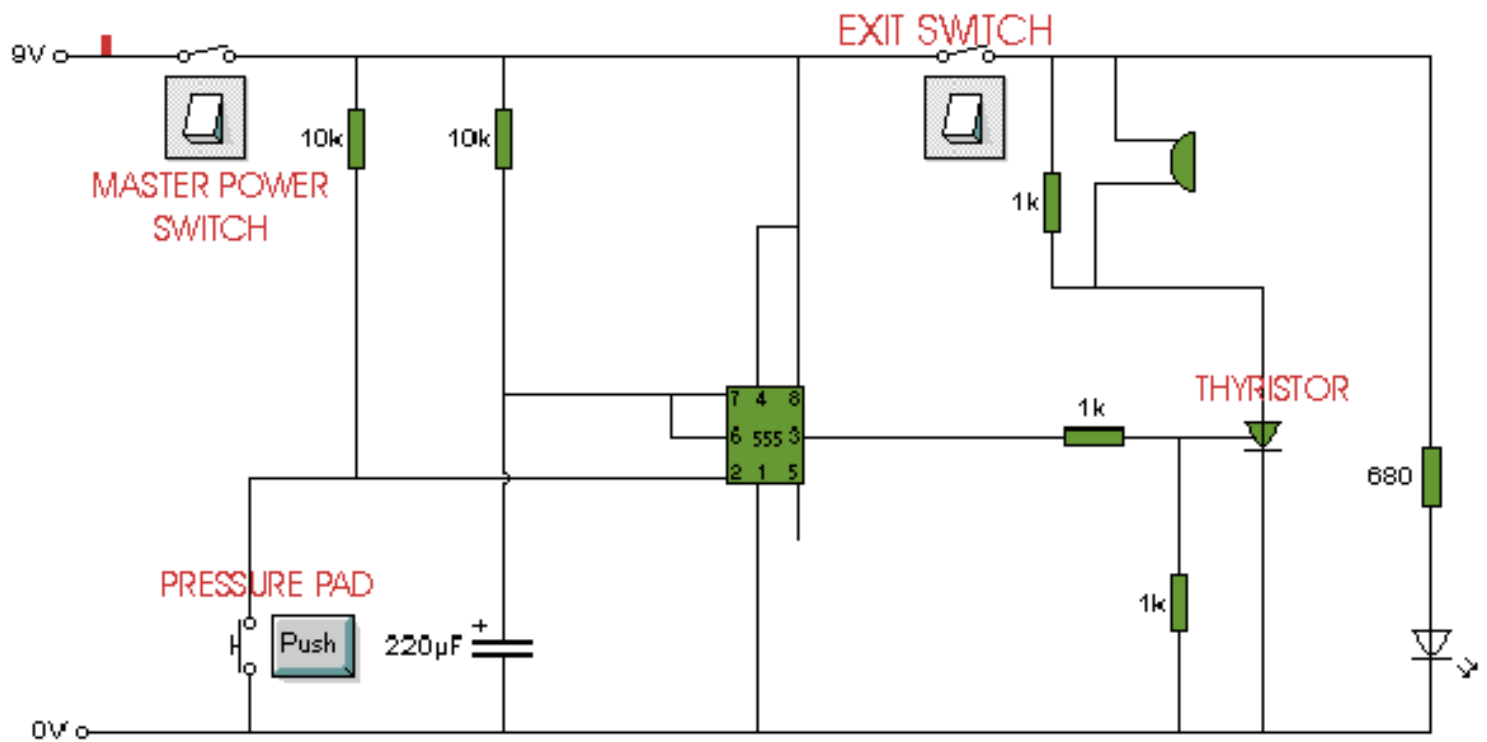

1. Draw the symbol for a thyristor.
2. Explain how a thyristor works.
3. Draw a circuit which includes a thyristor and explain how the circuit works.

[CLICK HERE FOR INDEX PAGE](#)

ANALOGUE AND DIGITAL SYSTEMS

V. Ryan © 2002

Electrical signals are in two forms;

Analogue signals

Digital signals

Analogue signals: A good example of an analogue signal is the loud-speaker of a stereo system. When the volume is turned up the sound increases slowly and constantly.

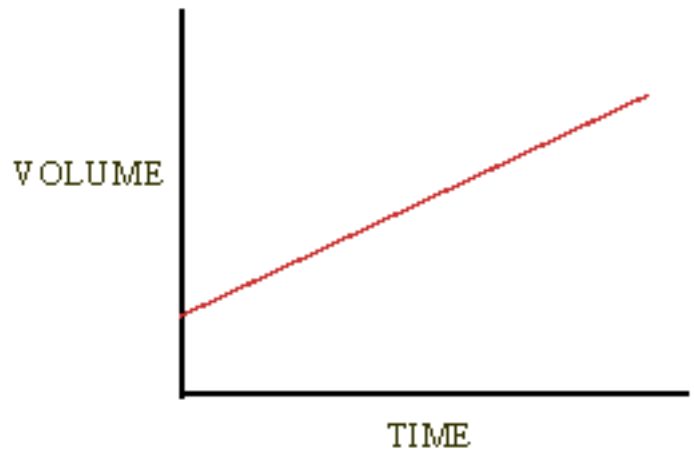

This graph is typical of analogue signals.

Digital signals: A good example of a digital signal is morse code. The signal is sent as a series of 'on' and 'off' pulses. The signal is either present or it is not.

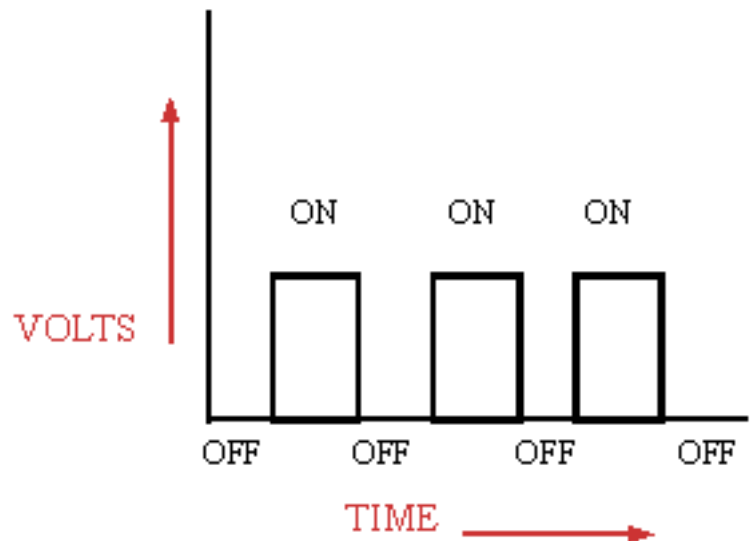

This graph is typical of digital signals

Both analogue and digital systems can be used as sensors. A thermistor is analogue as resistance slowly changes, a micro-switch is digital, as it is 'on' or 'off'.

Computers are digital devices and the various electronic parts communicate using 1's and 0's.

1 = ON

0 = OFF

**LIST EXAMPLES OF ANALOGUE
SYSTEMS**

LIST EXAMPLES OF DIGITAL SYSTEMS

[CLICK HERE FOR INDEX PAGE](#)

CONTROL SYSTEMS

V. Ryan © 2002

When designing a control system it is good practice to consider the overall system as a number of stages. For example;

A simple weather station can be looked upon as the following;

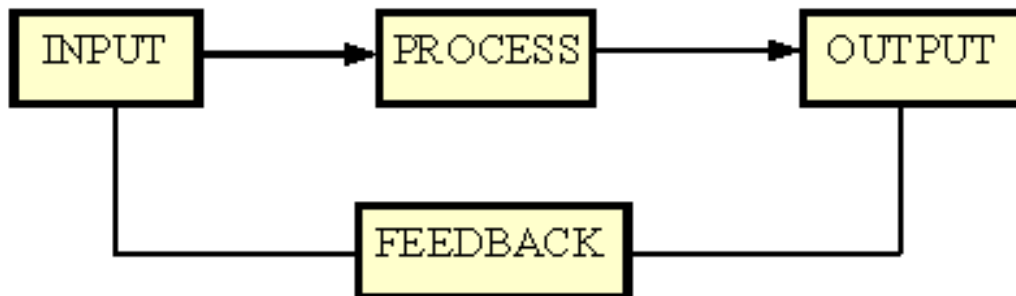

INPUT - the sensors (temperature, rain fall, humidity etc..)

PROCESS - the computer that analyses the incoming data.

OUTPUT - the final printout of temperature etc....

The system above is a **closed system** because it has **feedback**. A system that does not have feedback is an open system. The feedback in this system constantly monitors the incoming data from the weather sensors.

Example - Automatic Sprinkler System (for gardens):

When designing a system a good starting point is to think in terms of INPUT - PROCESS - OUTPUT and also include FEEDBACK.

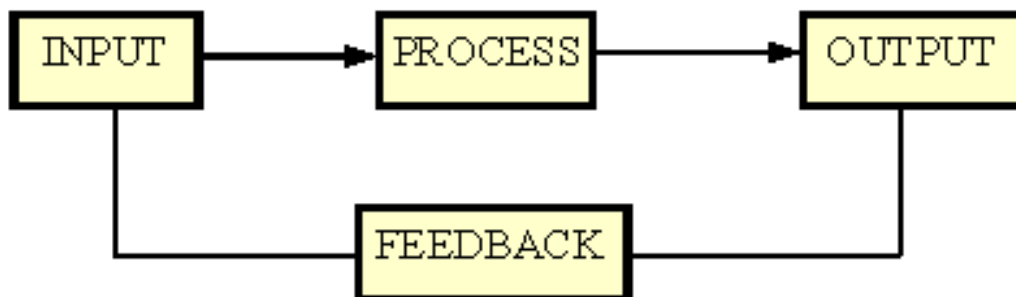

INPUT - How will the dryness of the soil be sensed? Perhaps an electrode can be used.

PROCESS - What device(s) will be needed to control the output? A computer could monitor incoming data and control the output, a simple program will be required.

OUTPUT - This may be a sprinkler device which is turned on when the computer detects the need for water.

FEEDBACK - Feedback is constant as the computer continually checks the moisture level of the soil.

Possible Solution:

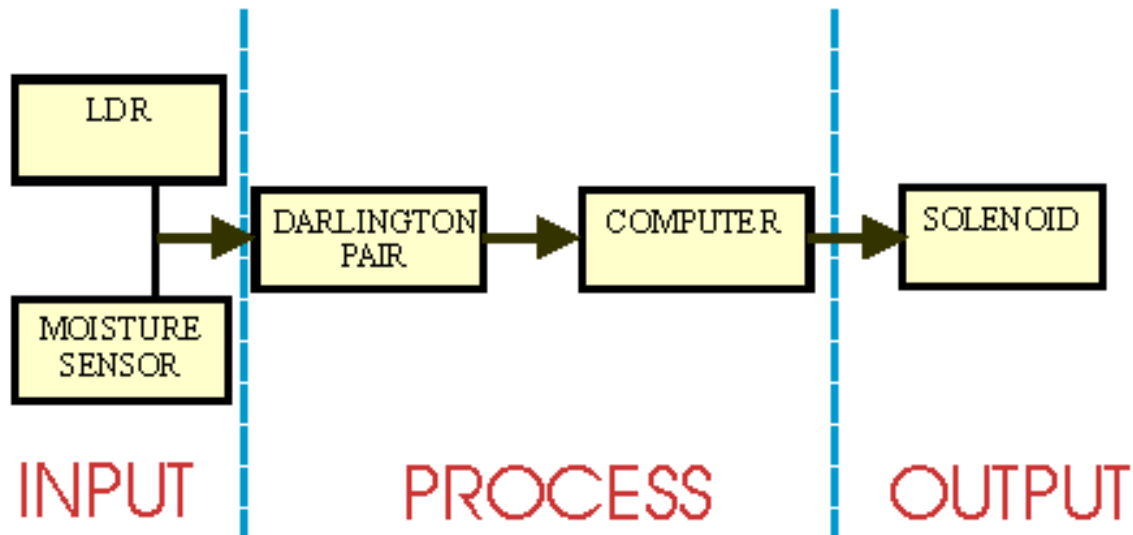

The LDR and the moisture sensor sense when water is needed. The Darlington pair is a simple electronic device that amplifies the signal sent by the sensors so that the computer can read it. The computer program then operates the solenoid, turning on the sprinkler which waters the soil.

INPUT DEVICES

The table below lists a number of INPUT devices. These can be either digital sensors or analogue (see analogue/digital section) and a 'system' normally starts with one of these.

INPUT DEVICES	SENSES/MEASURES
Light dependent resistors	light
Phototransistors	light
Thermocouples	temperature
Thermistors	temperature
Potentiometers	movement
Electrodes	humidity
Microphones	sound

Strain gauges	strain/bending
Switches	manual/mechanical

PROCESSING DEVICES

The table below lists a number of PROCESSING devices. These include computers and microprocessors as they are often used to detect a signal from a sensor.

PROCESSING DEVICE	EXAMPLE
Amplifiers	amplifies small inputs
Electronic switches	switches at different levels
Timers	switches after time delay
Gates; and/nand/or/nor	combines inputs
Counters	counts input pulses
Computer	detects the signal from input device
Micro-processor	detects the signal from input device

OUTPUT DEVICES

The table below lists a number of OUTPUT devices. These are usually devices such as motors or buzzers. For example, the output to an alarm system will be a buzzer or siren sounding.

OUTPUT DEVICES	EXAMPLE
Relays	controls higher voltages/circuits
Lamps	light
Buzzer/Bells	sound
Speakers	sound
Motors	movement (rotary)
Stepper motors	movement (precise rotary)
Solenoids	movement (linear)
Indicators	information

Circuits are usually designed through the systems approach as they usually have INPUTs a PROCESS and OUTPUTs.

[CLICK HERE TO SEE AN EXAMPLE OF A CIRCUIT DISPLAYED AS A SYSTEM](#)

[CLICK HERE FOR INDEX PAGE](#)

MODULAR ELECTRONICS

V. Ryan © 2002

When building a circuit it is a good idea to treat it as being made up of modules or parts. For example you may want a circuit to be composed of a switch and a bulb. To make it easier to design the circuit it is better if it is treated as two separate parts, a switch circuit and a bulb circuit. These are then joined together - to produce one completed circuit.

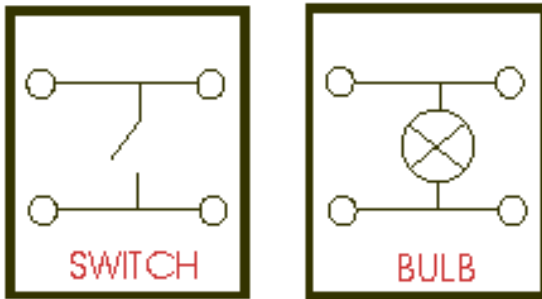

Two simple modules are seen opposite and they are clearly labelled. They can be rearranged to produce a complete circuit. When the switch is pressed the bulb lights (see below).

Each module has a top rail which is positive and a lower rail which is 0 volts or negative.

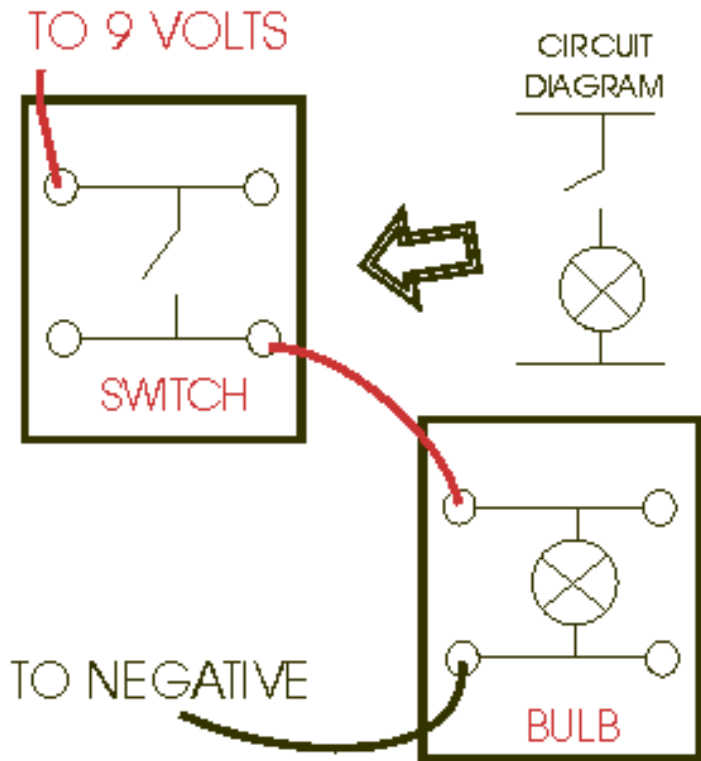

The modules are linked together by electrical wires and they fit into the positive or negative connections on the electronic boards/modules.

Different makes of electronic kits are available and each allows pupils to build up circuits, test them or experiment and finally to dismantle the modules so that another pupil can use them in the future.

In this way circuits can be built without the need to solder and without wasting time linking each individual component using traditional methods.

Below is a **temperature sensor circuit**. When the temperature falls the resistance of the thermistor falls and a bulb lights. Notice how the modules are put together to form the completed circuit.

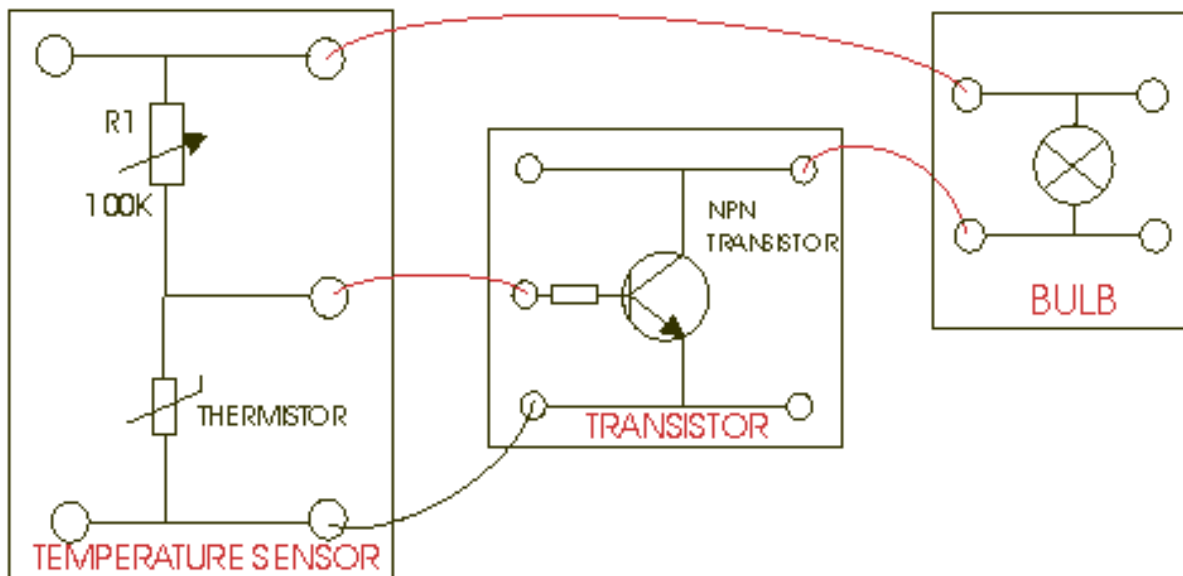

The **temperature sensor** is connected to a **transistor** which is then connected to a **bulb**. The transistor allows sharp switching of the bulb so that when the temperature falls the bulb comes on immediately and when it rises it goes off just as quickly. Can you draw the circuit as a circuit diagram ?

QUESTIONS

Below are some modules that can be put together to form completed circuits. Cut them out with a scissors and join them to complete the circuit questions on Sheet 3. If you require any modules that are not on this sheet, design them yourself and add them to the ones below.

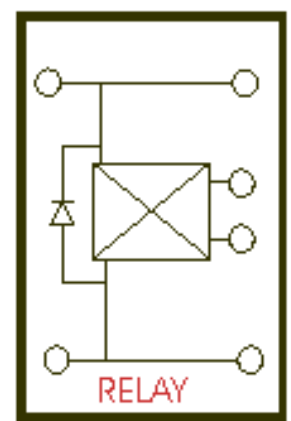
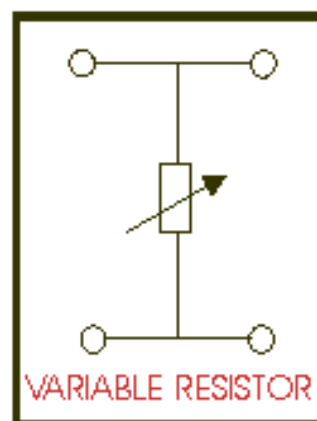
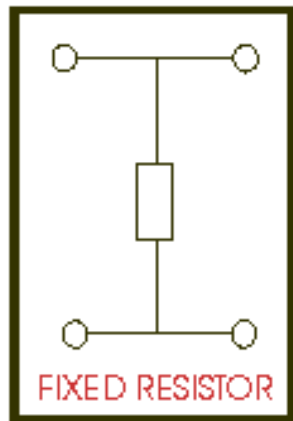
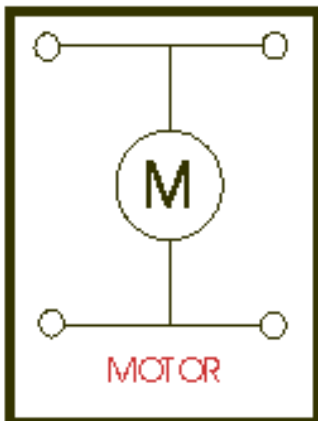
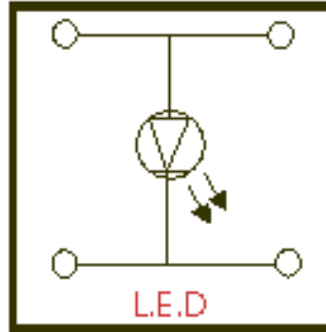
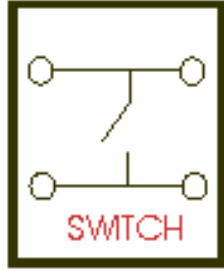
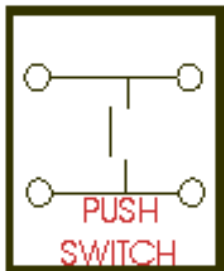
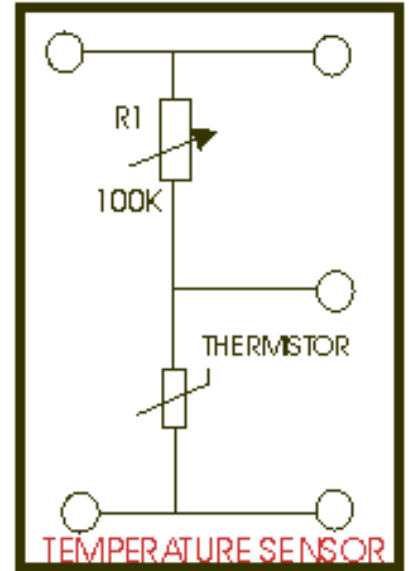
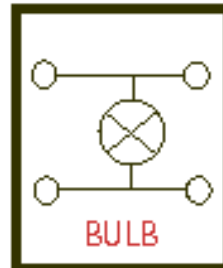
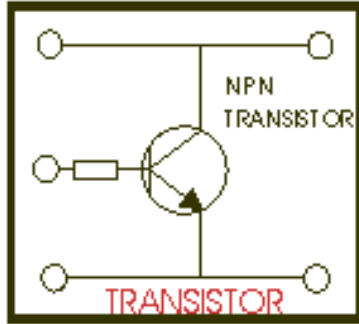
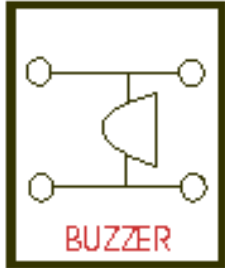
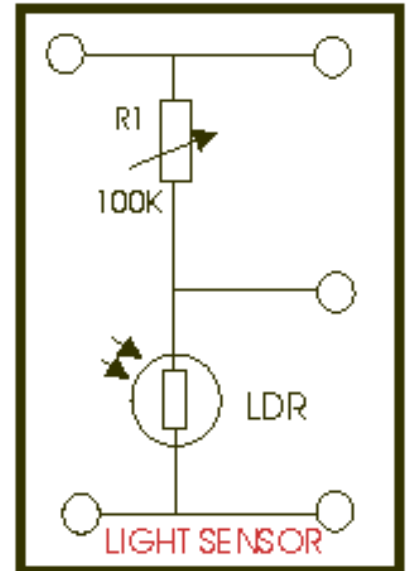
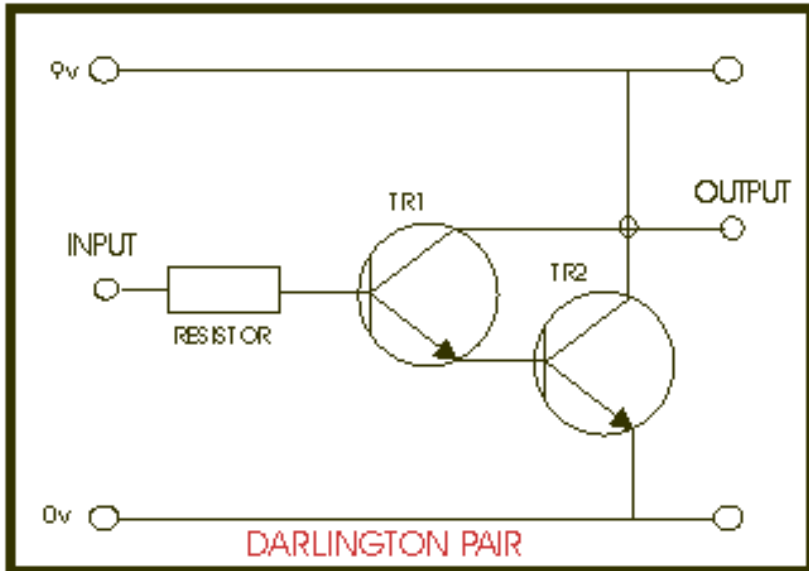

1. This question refers to the example 'temperature sensor circuit' near the top of this section.
 - A. Redesign the transistor module and bulb module so that they form one module.
 - B. Draw the completed temperature sensor and transistor/bulb modules connected together. Explain how the completed circuit works.
 - C. Draw a new temperature module, this time one that 'triggers' the transistor module when the temperature rises.

2. A. It is found that the bulb in the completed temperature circuit does not light because the output of the single transistor is too weak. Design a new module that will provide a stronger output.
 - B. What is this new module called ?
 - C. Explain how this circuit works.

3. Design a 'potential divider' module. The module is for a nine volt supply and should allow six volts to be drawn from it.

4. Design a simple game or toy for a very young child. It can involve sound, lights, a motor etc... Produce a simple, clear diagram and an explanation.

5. Design the circuit(s) for the toy using modules and then draw the completed circuit as a 'circuit diagram'. You may need to design your own individual modules. Look at the photocopied sheets that have been given out in previous weeks. (Suggestion - show your knowledge by using relays, LEDs, motors etc... alter sensors so that they can be incorporated). Note, it is possible to set up components in 'parallel' so that they work together. (example seen below).

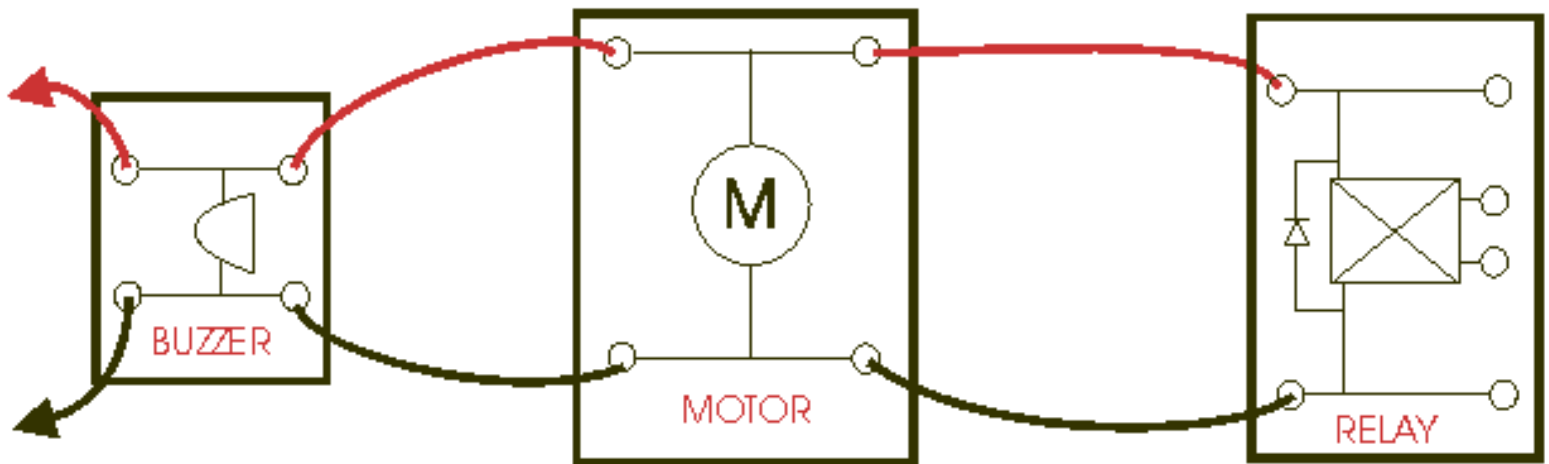

Remember to show your understanding of components such as relays and circuits that include 'Darlington Pairs' etc.... The examiner cannot give you marks for your understanding of electronics if you do not show it on paper.

[CLICK HERE FOR INDEX PAGE](#)

BREADBOARDS

V. Ryan © 2002

Breadboards are used to test circuits. Wires and components are simply pushed into the holes to form a completed circuit and power can be applied. One of the main advantages of using a breadboard is that the components are not soldered and if they are positioned incorrectly they can be moved easily to a new position on the board. On the breadboard ([diagram 1](#)) seen opposite, letters are used to identify vertical columns and numbers to identify horizontal rows.

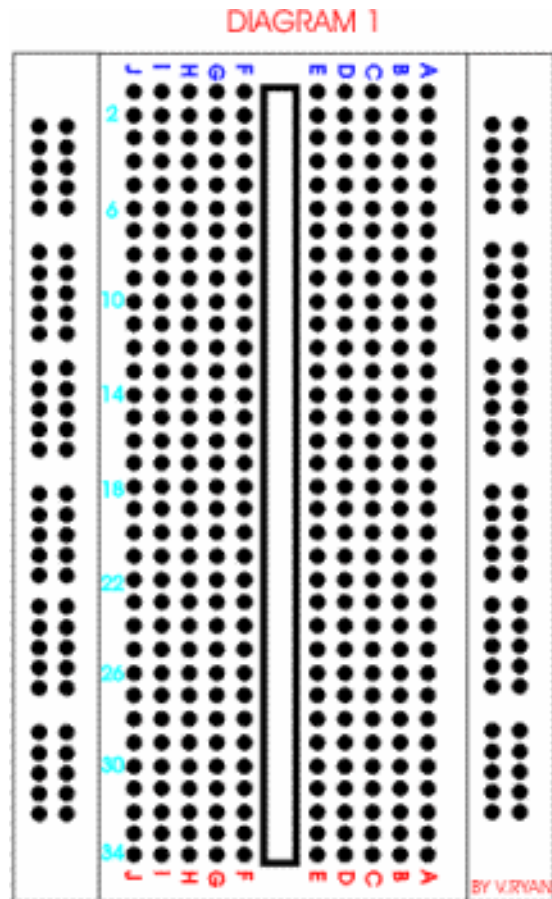
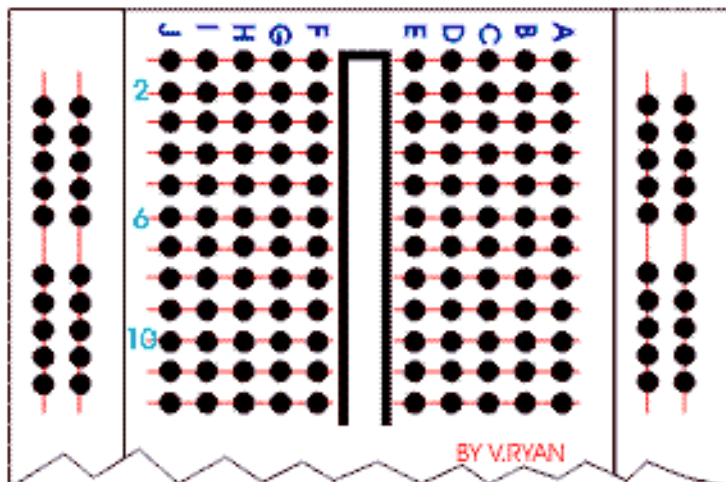
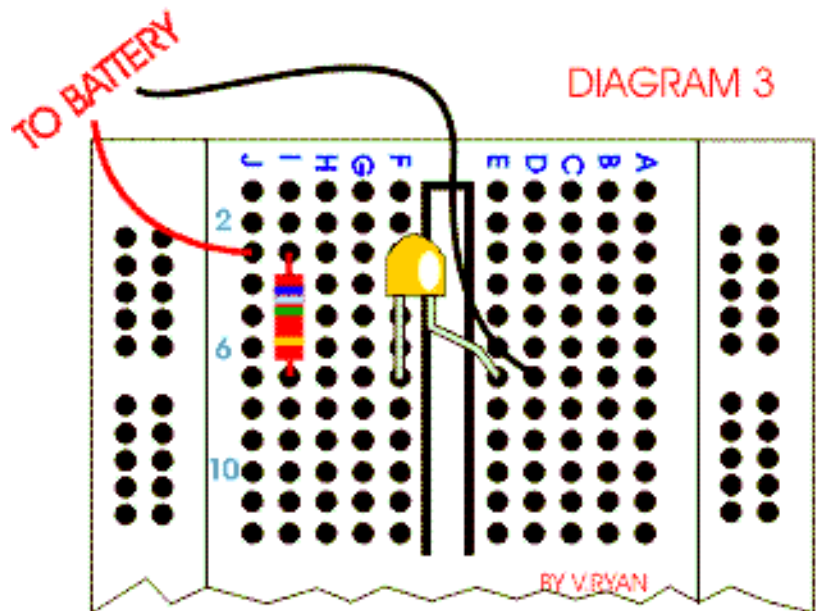

DIAGRAM 2



The red lines on [diagram 2](#) show how some vertical columns and horizontal rows are internally connected. When power is applied to the breadboard current flows along these internal connections.

Diagram 3 shows how a 380 ohm resistor and an LED are setup on a breadboard. When a 9 volt battery is attached the LED lights. Try replacing the resistor with a higher value such as a 680 ohm resistor. The resistance will be greater and the LED should shine less bright.



[CLICK HERE FOR INDEX PAGE](#)

THE 555 TIMER

V. Ryan © 2002

This integrated circuit is used for timing. Many circuits are composed of timers and the most common of them all is the 555 Integrated Circuit. The 555 integrated circuit (IC) is a chip that is used in many school projects and commercially made items such as video recorders and timers. You must understand the basic workings of this important IC.

The 555 has eight pins (legs) but the function of two are very important. These are pin two and three.

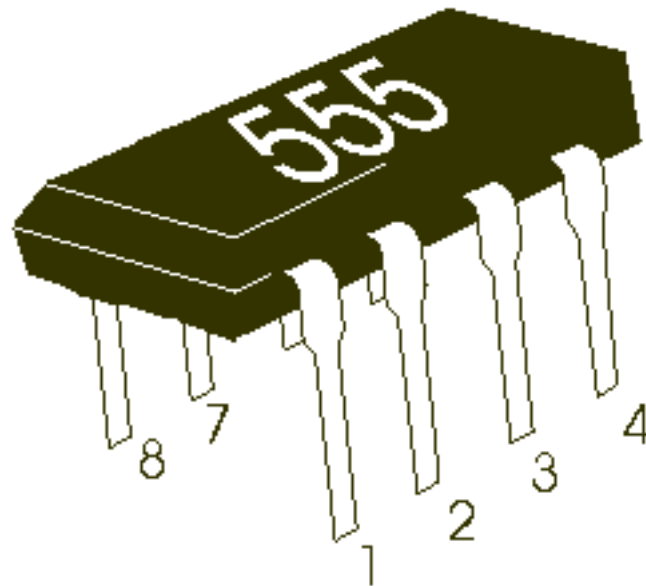

PIN 2. This pin is where the current / voltage enters the chip and starts the timing sequence or starts to count.

PIN 3. This is where the current comes out after the timer has completed counting.

A SIMPLE 555 CIRCUIT

The circuit below is a simplified version of a 555 circuit. It is a timer. When the switch is pressed a current / voltage goes into the IC through pin two (the input pin). The chip starts counting and when it has finished counting it ‘pulses’ a current or voltage from pin three (the output pin). This voltage from pin three switches a transistor and allows the LED to light.

The time from pressing the switch to the LED lighting could be anything from 1 second to twenty minutes.

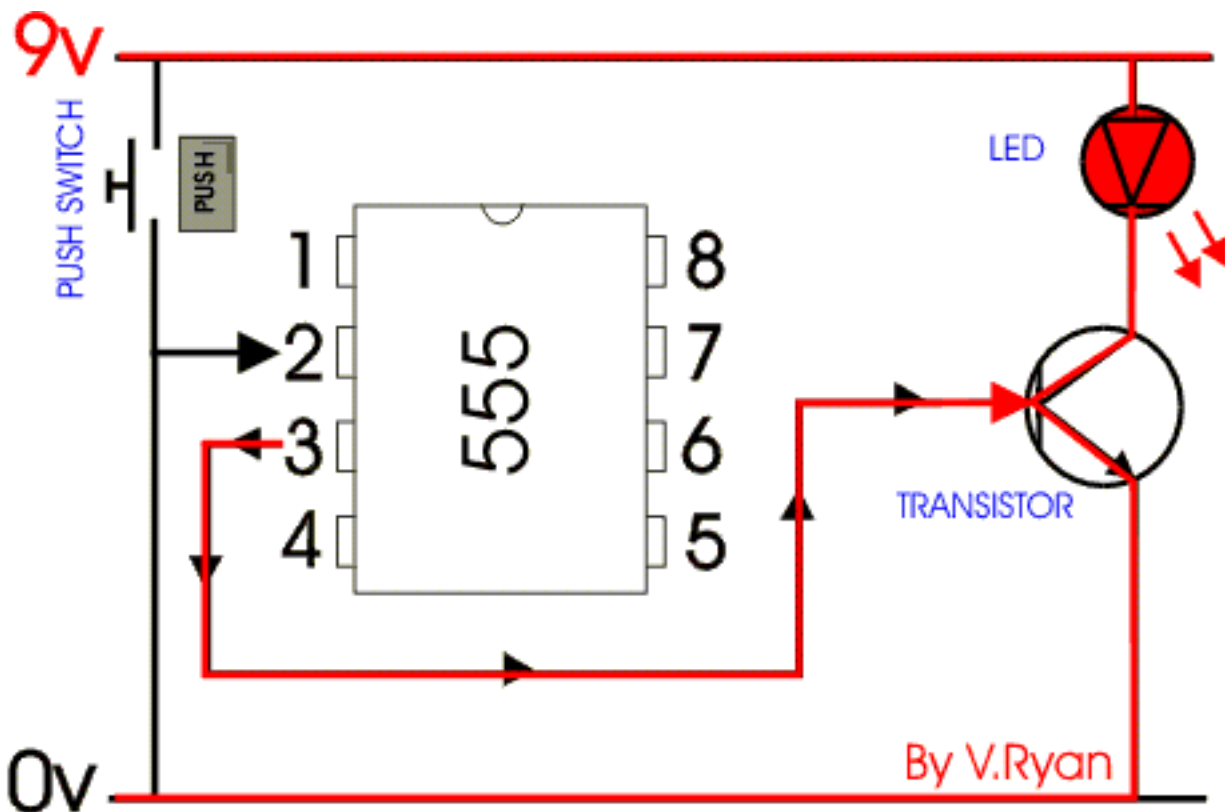

A 555 will switch on a range of components not only LEDs. For example, it can switch on a relay which then allows a second circuit to work.

The circuit shown above is a simple version of a real 555 circuit. The real circuit includes resistors and capacitors. ([See following sheets](#)).

[CLICK HERE FOR INDEX PAGE](#)

THE 555 TIMER - ASTABLE CIRCUIT

V. Ryan © 2002

When the 555 IC is used to produce an **ASTABLE** circuit - it will continually pulse until power is removed. Astable circuits can be used to flash lights/LEDs on and off or to turn a buzzer on and off repeatedly. They are also used in many more school based circuits.

Look at the circuit drawn below. Pins 6 and 2 are connected and go to the negative (0 volts). This is the easiest way of recognising that a 555 IC has been set up as astable.

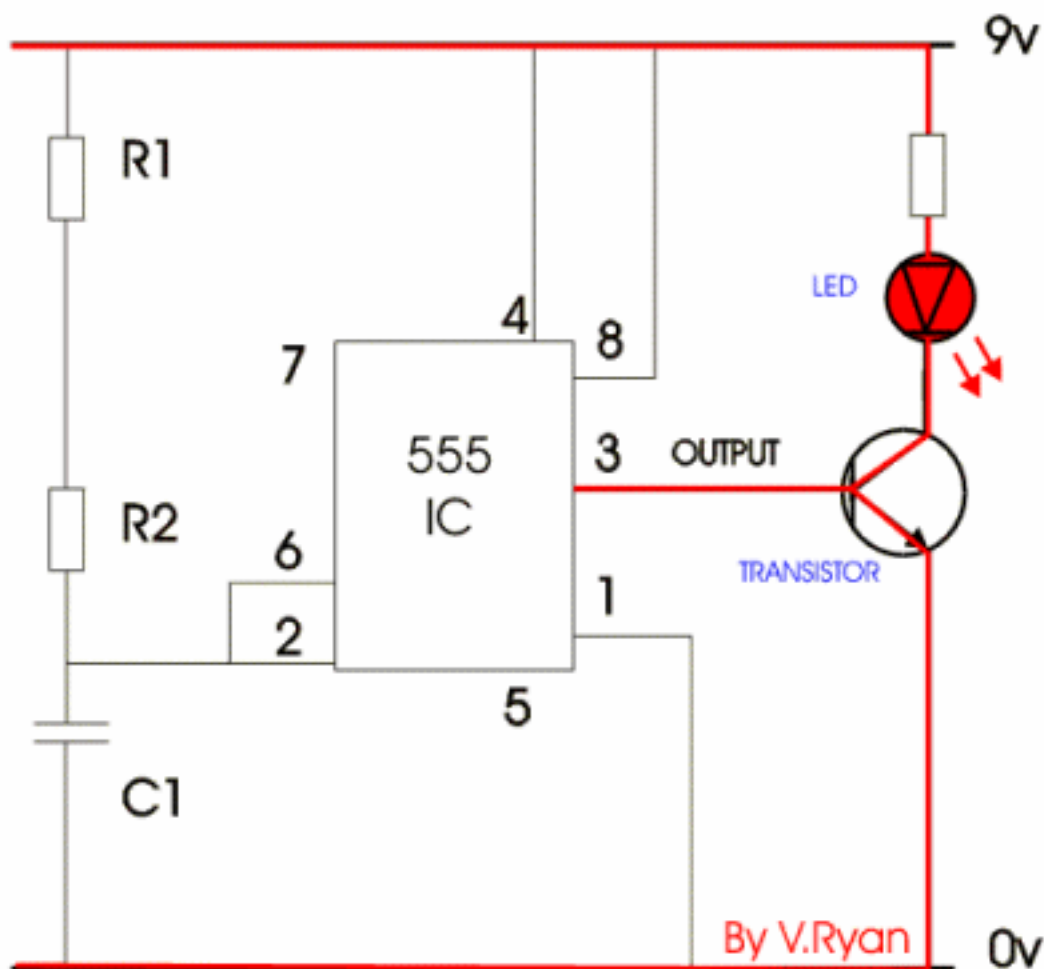

[CLICK HERE FOR INDEX PAGE](#)

THE 555 TIMER - MONOSTABLE CIRCUIT

V. Ryan © 2002

When the 555 IC is used to produce an **MONOSTABLE** circuit - it will only pulse once. Monostable circuits can be used to turn lights/LEDs on or off just once. They are also used in many more school based circuits.

Look at the circuit drawn below. Pins 6 and 7 are connected and go to the positive (+9 volts). This is the easiest way of recognising that a 555 IC has been set up as monostable.

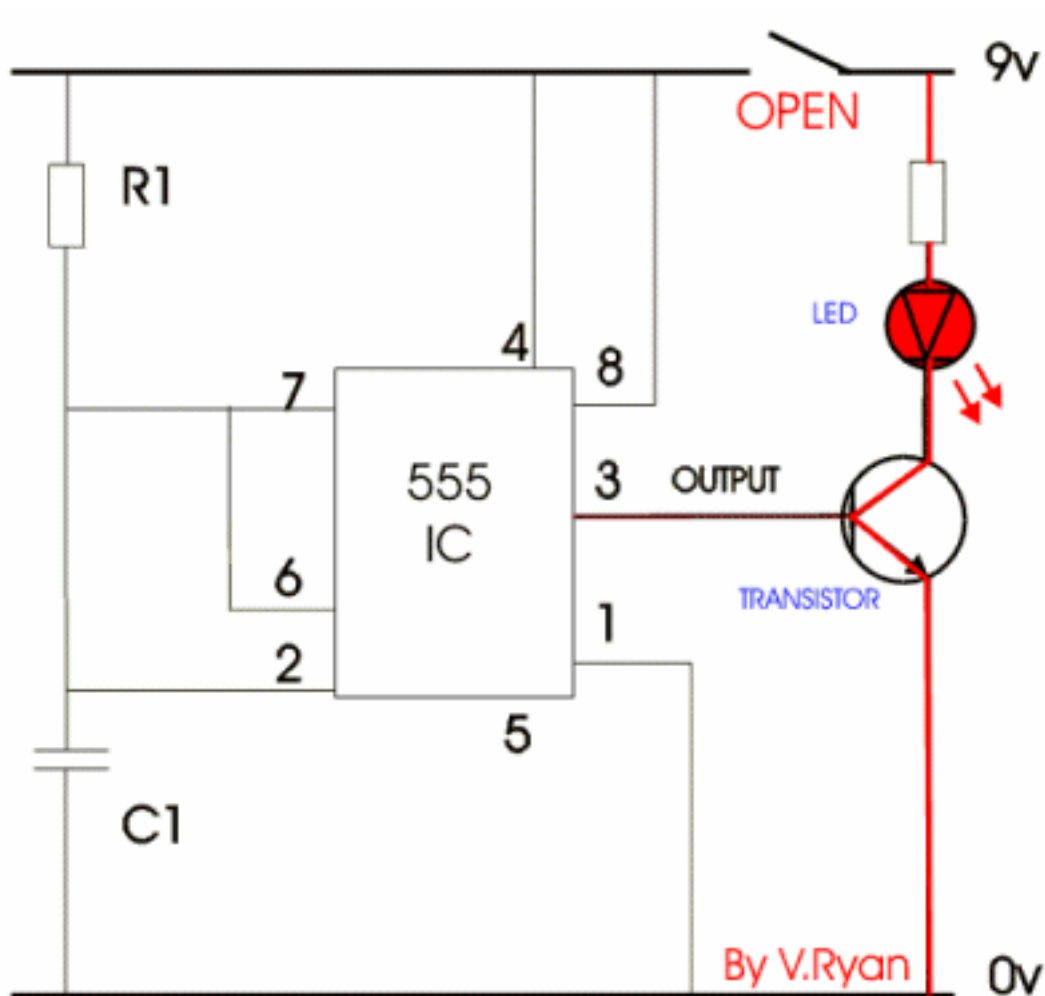

When the switch is pressed current flows into pin 2. Current then flows out of pin 3 switching the transistor. Current can now flow from +9 volts to -0 volts and the LED lights. In this *monostable* circuit when the switch is pressed the LED only lights once. The switch has to be pressed each time for the LED to light. In this example the LED stays on for approximately 8 seconds.

[CLICK HERE FOR INDEX PAGE](#)

THE 555 MONOSTABLE CIRCUIT IN **DETAIL**

V. Ryan © 2002

Electronic timers are central to school projects. You will find as you develop your circuits that the timer circuit can be adapted to suit many purposes. There are several reliable timers but the 555 timer is the most common. Whether you are putting together an alarm or a circuit to activate a computer, a timer is the common component.

The 555 timer IC (integrated circuit) is very stable, relatively cheap and reliable. It may be used as monostable or astable.

MONOSTABLE

Monostable means that once the circuit is switched on it will time once and then stop. In order to start it again it must be switched on manually a second time.

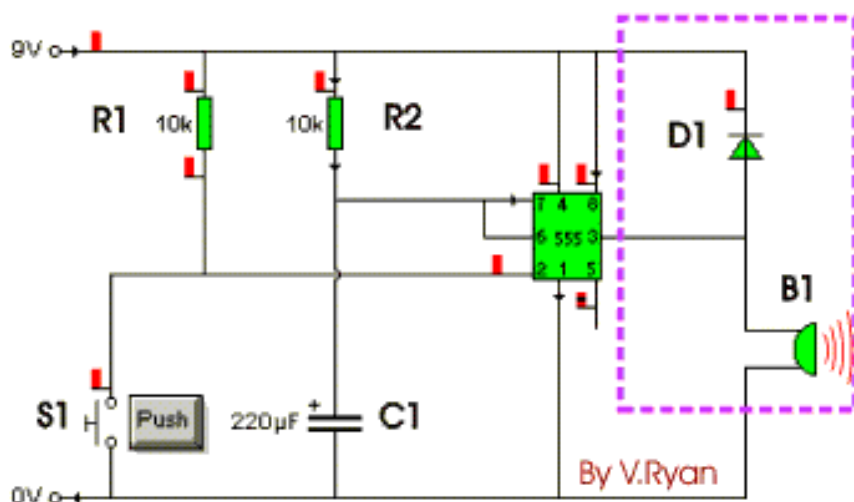

In the circuit drawn opposite, the 555 timer is set to turn on the buzzer when the push switch is pressed; the buzzer sounds for approximately 8 seconds. This is a monostable circuit as it works only once. The switch must be pressed again for the buzzer to sound again.

On the diagram above if the components 'boxed in' by the dotted line are removed and the alternative components (shown on the right) are added - the 555 timer circuit can be used to energise a relay.

The timer can now be used to trigger a relay which then allows another circuit to work. In this case the timer holds the relay closed for a preset amount of time allowing the second circuit to work and then switches the relay open, which stops the secondary circuit.

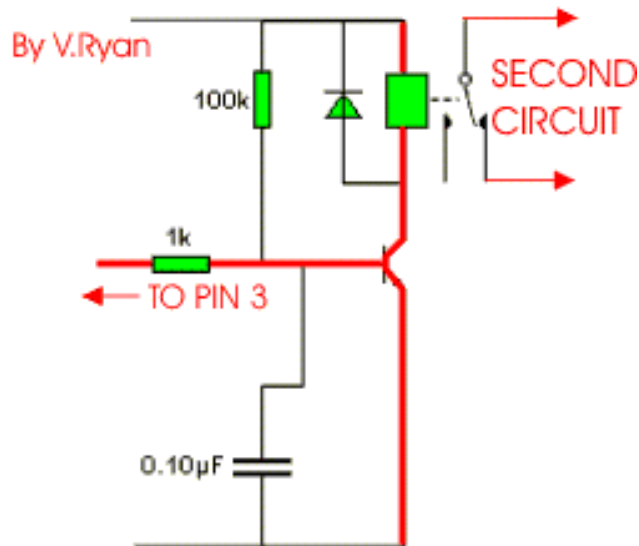

WHAT THE 'PINS' OF THE 555 ACTUALLY DO

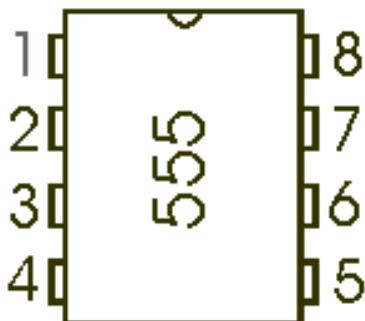
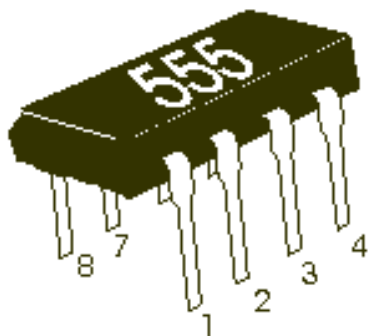

The pin (leg) that triggers the 555 IC is leg two. In other words leg two starts the timing sequence once a voltage is applied to it and after the 555 timer has ended its timing sequence a signal (output) is sent down leg three. In the circuit at the top of this page, the signal down leg three starts the buzzer. The variable resistor VR1 can be used to increase or decrease the timing cycle.

FUNCTION	555
GROUND	1
TRIGGER	2
OUTPUT	3
RESET	4
CONTROL V	5
THRESHOLD	6
DISCHARGE	7
Vcc	8

TABLE OF PIN FUNCTIONS

[CLICK HERE FOR INDEX PAGE](#)

555 ASTABLE CIRCUIT - BREAD BOARD

V. Ryan © 2002

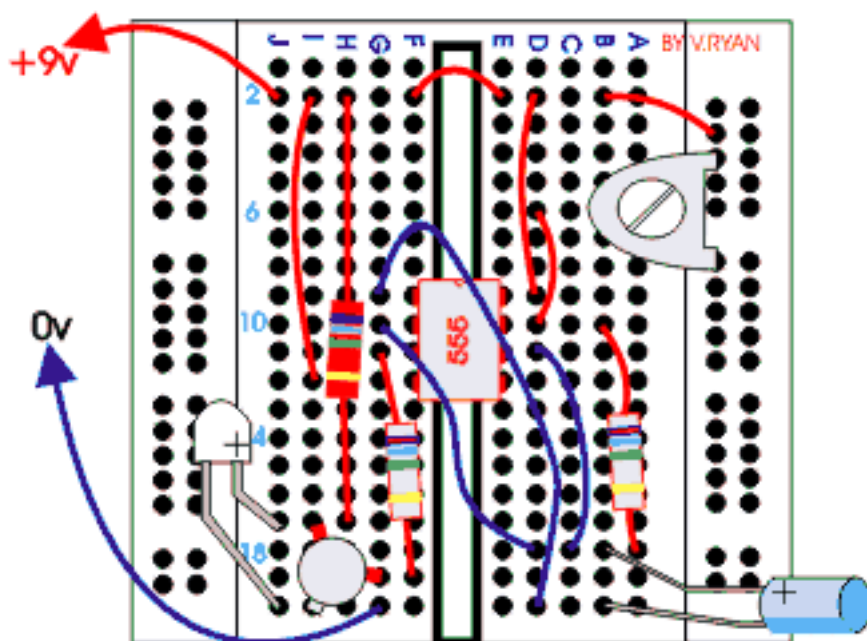

Components:

- One 555 IC
- 270 ohm resistor from +9v to the collector of the NPN transistor.
- Two 1K resistors
- One NPN transistor (try any alternative).
- One 100K preset resistor.
- One 47uf capacitor
- Black and red wire.
- One LED

Using a breadboard and components listed above, put together the astable 555 timer circuit. Test the circuit to check that it works. Usually any faults are due to wires, components or pins/legs of components in the wrong slots. The information below explains in detail how the timer works.

Astable means that the 555 can operate repeatedly, it will switch on, then off, then on, then off, continually. The 555 is sometimes called an oscillator.

This is a typical 555 astable circuit that drives an LED. It is known as a LED flasher as the LED flashes on and off. The number of flashes per minute can be altered by turning the preset resistor.

Remember the 555 is activated by current at pin two and the output is through pin three. Altering the preset resistor alters the time between 'pulses' at pin three. The pulse at pin three switches the transistor which allows the LED to come on.

The LED flashes on and off because with this astable circuit the pulses from pin three are repeated until the power is switched off completely.

[CLICK HERE FOR ELECTRONICS INDEX PAGE](#)

[CLICK HERE FOR INDEX PAGE](#)

THE 555 ASTABLE CIRCUIT IN DETAIL

V. Ryan © 2002

Electronic timers are central to school projects. You will find as you develop your circuits that the timer circuit can be adapted to suit many purposes. There are several reliable timers but the 555 timer is the most common. Whether you are putting together an alarm or a circuit to activate a computer, a timer is the common component.

The 555 timer IC (integrated circuit) is very stable, relatively cheap and reliable. It may be used as monostable or astable.

Astable means that the 555 can operate repeatedly, it will switch on, then off, then on, then off, continually. The 555 is sometimes called an oscillator.

This is a typical 555 astable circuit that drives an LED. It is known as a LED flasher as the LED flashes on and off. The number of flashes per minute can be altered by turning the variable resistor.

Remember the 555 is activated by current at pin two and the output is through pin three. Altering the variable resistor alters the time between 'pulses' at pin three. The pulse at pin three switches the transistor which allows the LED to come on. The LED flashes on and off because with this astable circuit the pulses from pin three are repeated until the

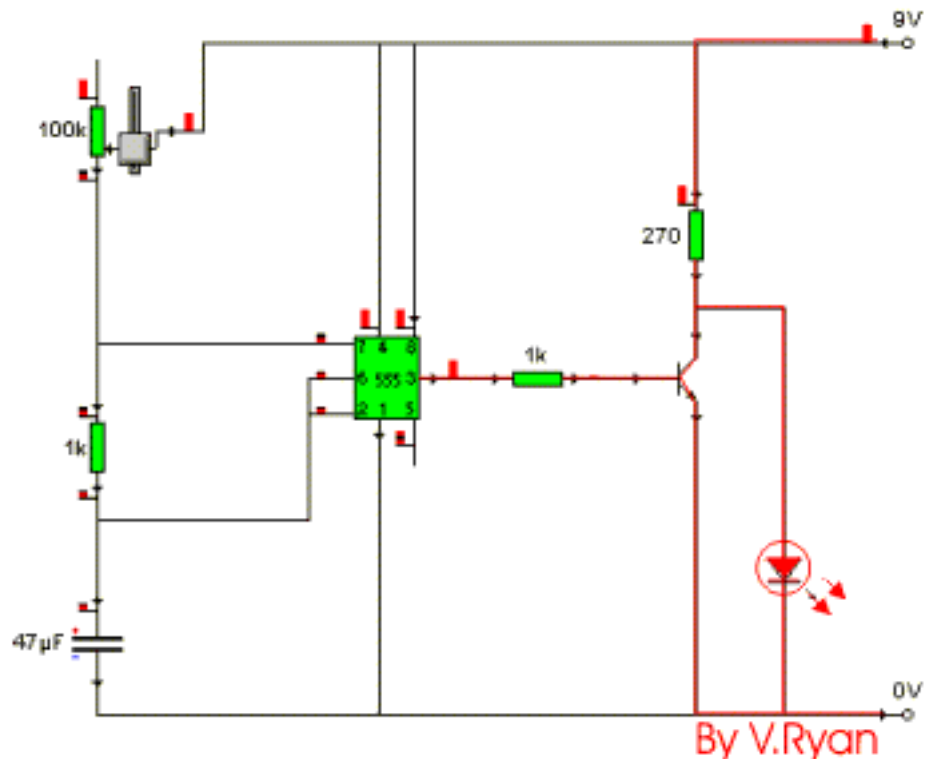

power is switched off completely.

This 555 circuit is very similar to the one above and it is called a 'pulse generator'. Circuits like this are often used to produce a pulse or signal that will start a second circuit. This can be seen in a simple alarm.

Our alarm consists of two circuits, one is a 555 pulse generator and the other detects the pulse. If the pulse is removed a buzzer on the second circuit sounds.

This type of circuit could be useful on a door. When the door is shut the alarm is turned on. The first 555 circuit generates a pulse (positioned on the door frame) and the second circuit detects the pulse and is positioned on the door itself. If the door is opened the connection between the two circuits is broken. The second circuit can not detect a pulse and so the buzzer sounds.

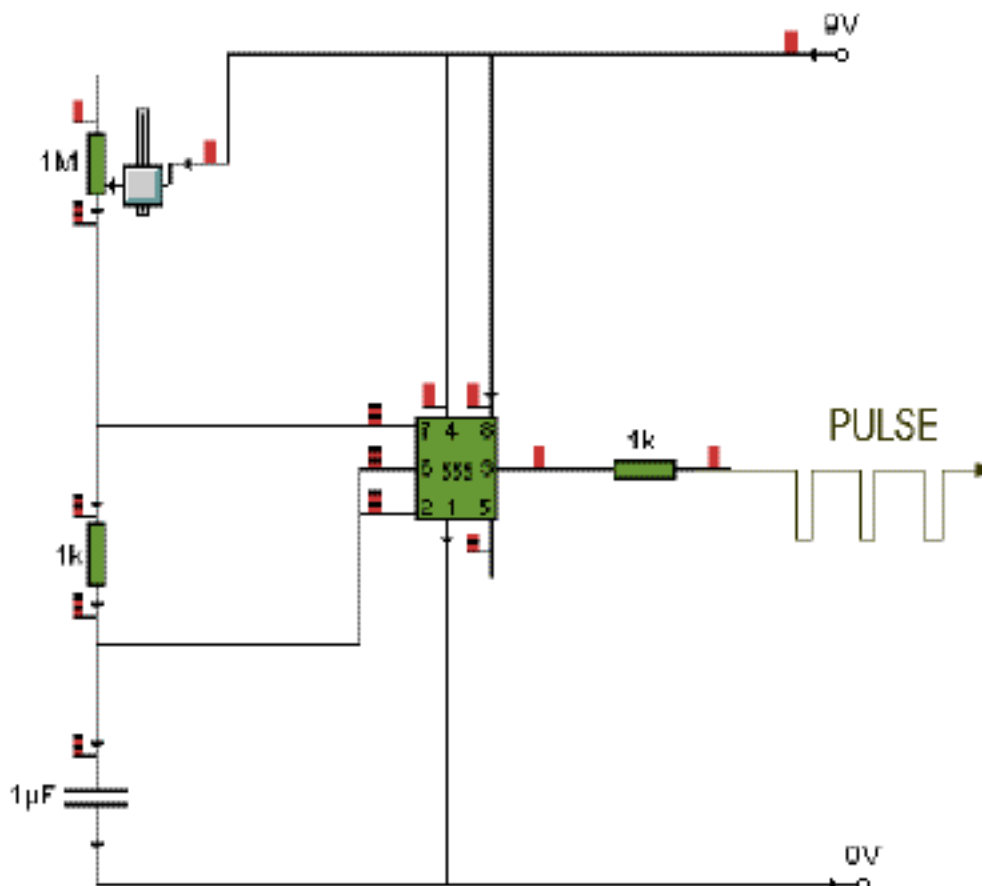

ALARM

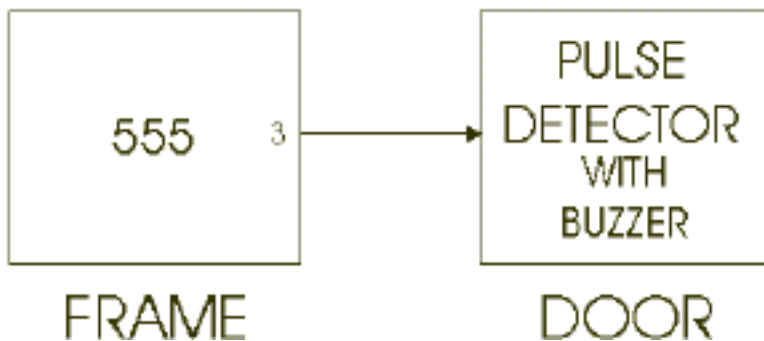

[CLICK HERE FOR INDEX PAGE](#)

THE 741 OPERATIONAL AMPLIFIER

V. Ryan © 2002

The Operational Amplifier is probably the most versatile Integrated Circuit available. It is very cheap especially keeping in mind the fact that it contains several hundred components. The most common Op-Amp is the 741 and it is used in many circuits.

The OP AMP is a 'Linear Amplifier' with an amazing variety of uses. Its main purpose is to amplify (increase) a weak signal - a little like a Darlington Pair.

The OP-AMP has two inputs, INVERTING (-) and NON-INVERTING (+), and one output at pin 6.

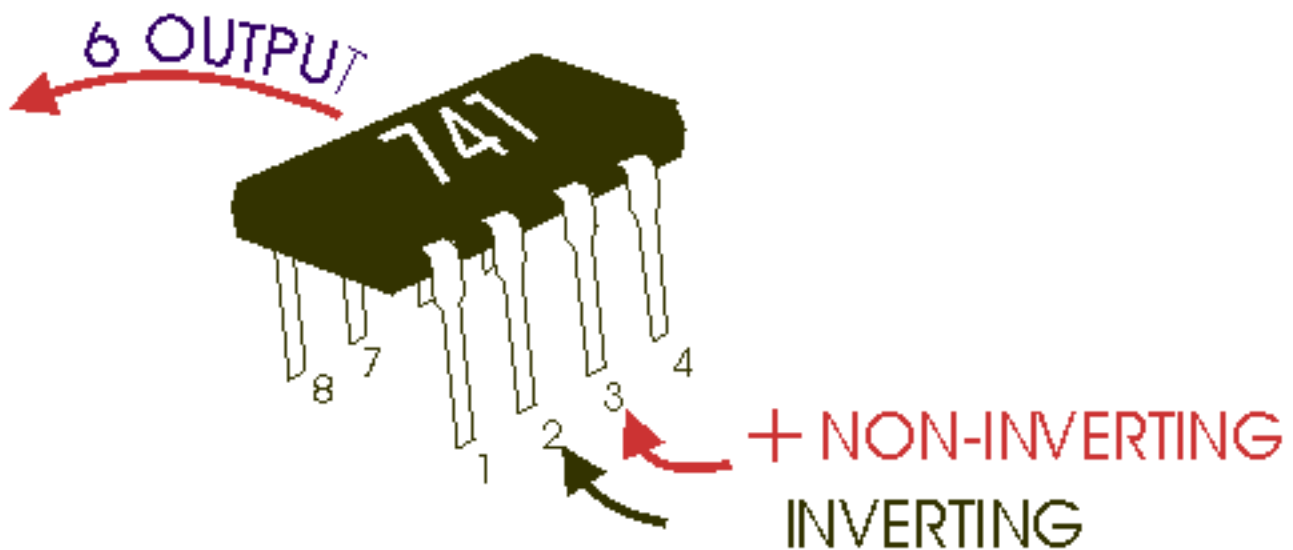

The chip can be used in a circuit in two ways. If the voltage goes into pin two then it is known as an INVERTING AMPLIFIER.

If the voltage goes into pin three then the circuit becomes a NON-INVERTING AMPLIFIER.

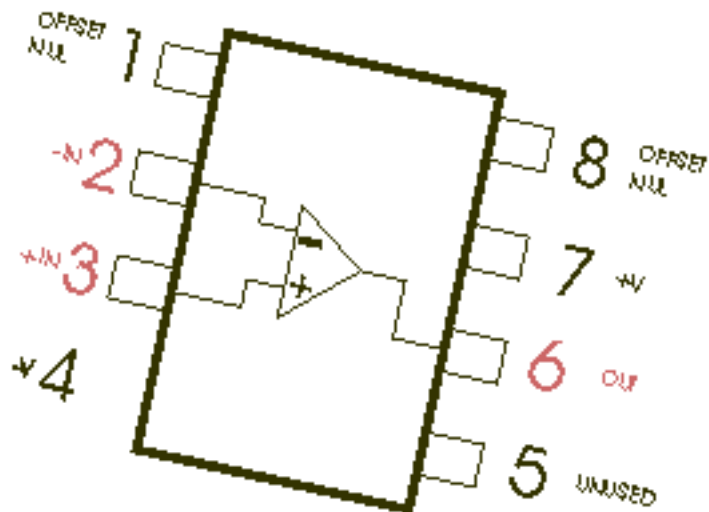

The 741 integrated circuit looks like any other 'chip'. However, it is a general purpose OP-AMP. You need only to know basic information about its operation and use. The diagram opposite shows the pins of the 741 OP-AMP. The important pins are 2, 3 and 6 because these represent inverting, non-inverting and voltage out. Notice the triangular diagram that represents an Op-Amp integrated circuit.

THE 741 IS USED IN TWO WAYS

1. An inverting amplifier. Leg two is the input and the output is always reversed.

In an inverting amplifier the voltage enters the 741 chip through leg two and comes out of the 741 chip at leg six. If the polarity is positive going into the chip, it negative by the time it comes out through leg six. The polarity has been 'inverted'.

2. A non-inverting amplifier. Leg three is the input and the output is not reversed.

In a non-inverting amplifier the voltage enters the 741 chip through leg three and leaves the 741 chip through leg six. This time if it is positive going into the 741 then it is still positive coming out. Polarity remains the same.

[CLICK HERE FOR INDEX PAGE](#)

NON-INVERTING AND INVERTING 741 AMPLIFIERS

V. Ryan © 2002

- An inverting amplifier** - Leg two is the input and the output is always reversed or inverted.
- A Non-inverting amplifier** - Leg three is the input and the output is not reversed.

Opposite is a diagram of an **INVERTING AMPLIFIER**. This means that if the voltage going into the 741 chip is positive, it is negative when it comes out of the 741. In other words it reverses polarity (inverts polarity).

Two resistors are needed to make the 741 work as an amplifier, R1 and R2. In most text books diagrams like this are used to represent the 741.

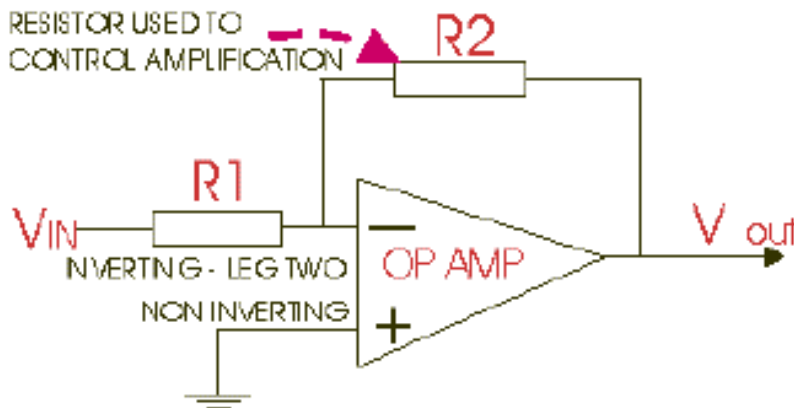

HOW TO CALCULATE THE 'GAIN'

An operational amplifiers purpose is to amplify a weak signal and this is called the GAIN.

INVERTING AMPLIFIER

$$\text{GAIN (AV)} = -R2 / R1$$

Example : if R2 is 100 kilo-ohm and R1 is 10 kilo-ohm the gain would be :

$$-100 / 10 = -10 \text{ (Gain AV)}$$

If the input voltage is 0.5v the output voltage would be :

$$0.5\text{v} \times -10 = -5\text{v}$$

NON-INVERTING AMPLIFIER

$$\text{GAIN (AV)} = 1 + (R2 / R1)$$

Example : if R2 is 1000 kilo-ohm and R1 is 100 kilo-ohm the gain would be :

$$1 + (1000/100) = 1 + 10$$

OR

$$\text{GAIN (AV)} = 11$$

If the input voltage is 0.5v the output voltage would be :

$$0.5 \times 11 = 5.5\text{v}$$

INVERTING AMPLIFIER

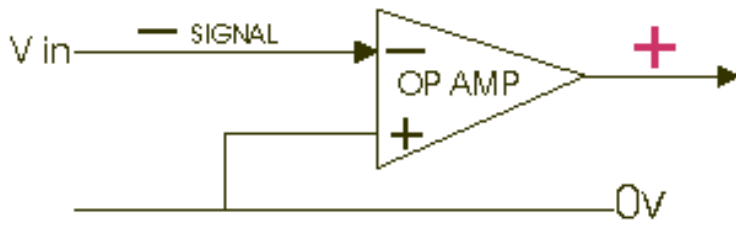

NON-INVERTING AMPLIFIER

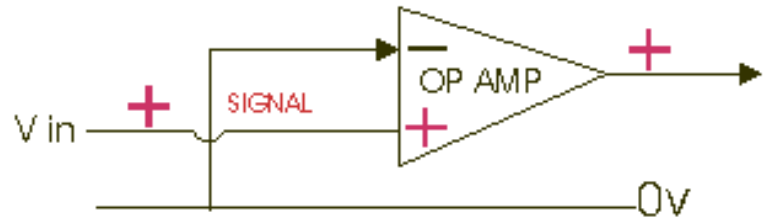

The polarity of a signal is reversed at the output, pin six.

A negative input becomes a positive output.

A signal applied keeps its polarity at the output, pin six.

A positive input remains a positive output.

[CLICK HERE FOR INDEX PAGE](#)

OP-AMPS AS COMPARATORS

V. Ryan © 2002

Below are some examples of 741 I.C. based circuits. However, this time the 741 is used as a comparator and not an amplifier. The difference between the two is small but significant. Even if used as a comparator the 741 still detects weak signals so that they can be recognised more easily. It is important to understand these circuits as they very regularly appear in examinations.

A 'comparator' is a circuit that compares two input voltages. One voltage is called the reference voltage (V_{ref}) and the other is called the input voltage (V_{in}).

When V_{in} rises above or falls below V_{ref} the output changes polarity (+ becomes -).

Positive is sometimes called *HIGH*.

Negative is sometimes called *LOW*.

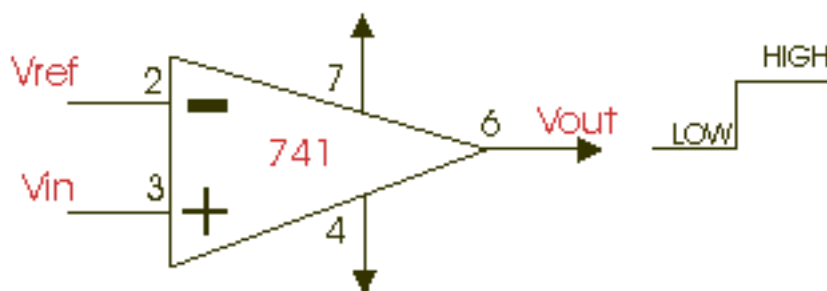

EXAMPLE CIRCUIT - LIGHT ACTIVATED ALERTER

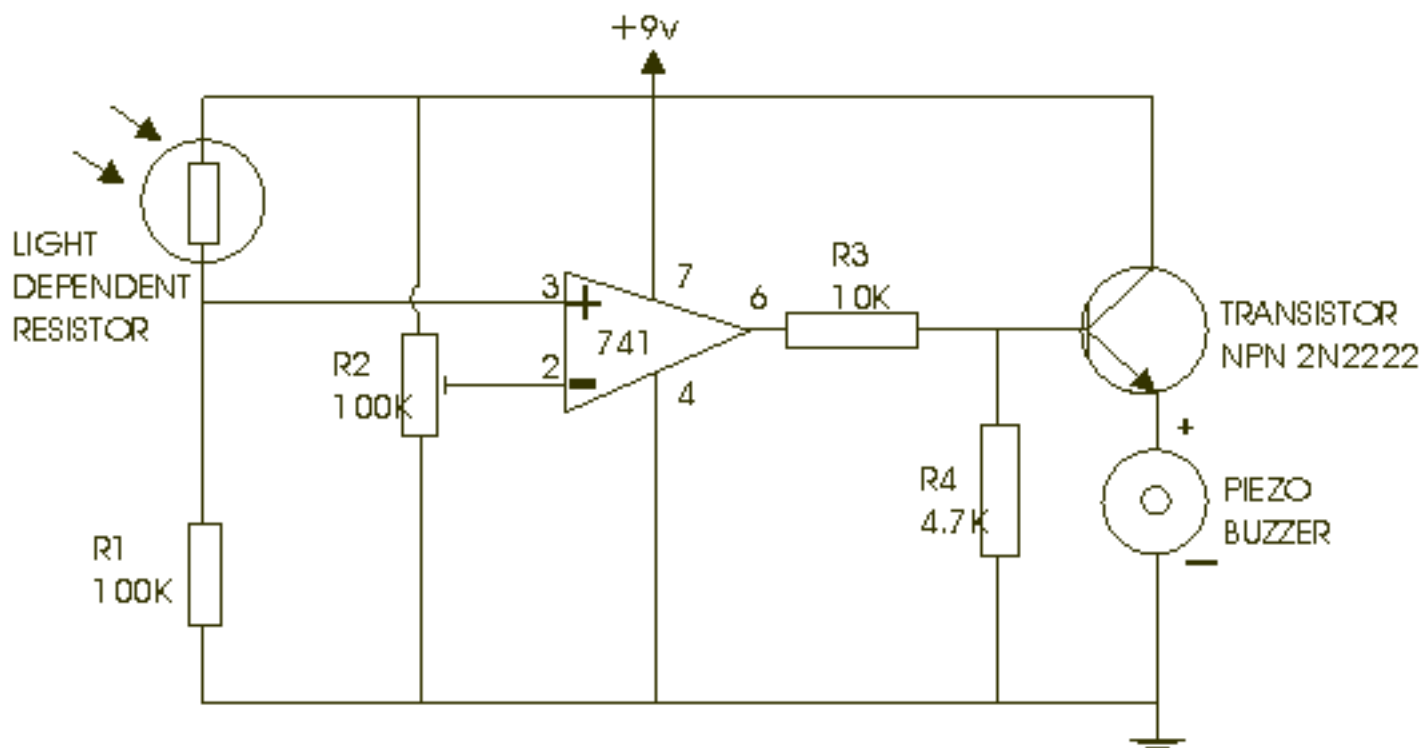

The buzzer emits a tone when light falls on the light dependent resistor. Resistor 2 controls the sensitivity of the circuit.

The 741 is working as a comparator and the piezo buzzer sounds when the output from the 741 goes 'low' or in other words, changes from a positive to a negative.

EXAMPLE CIRCUIT - DARK ACTIVATED ALERTER

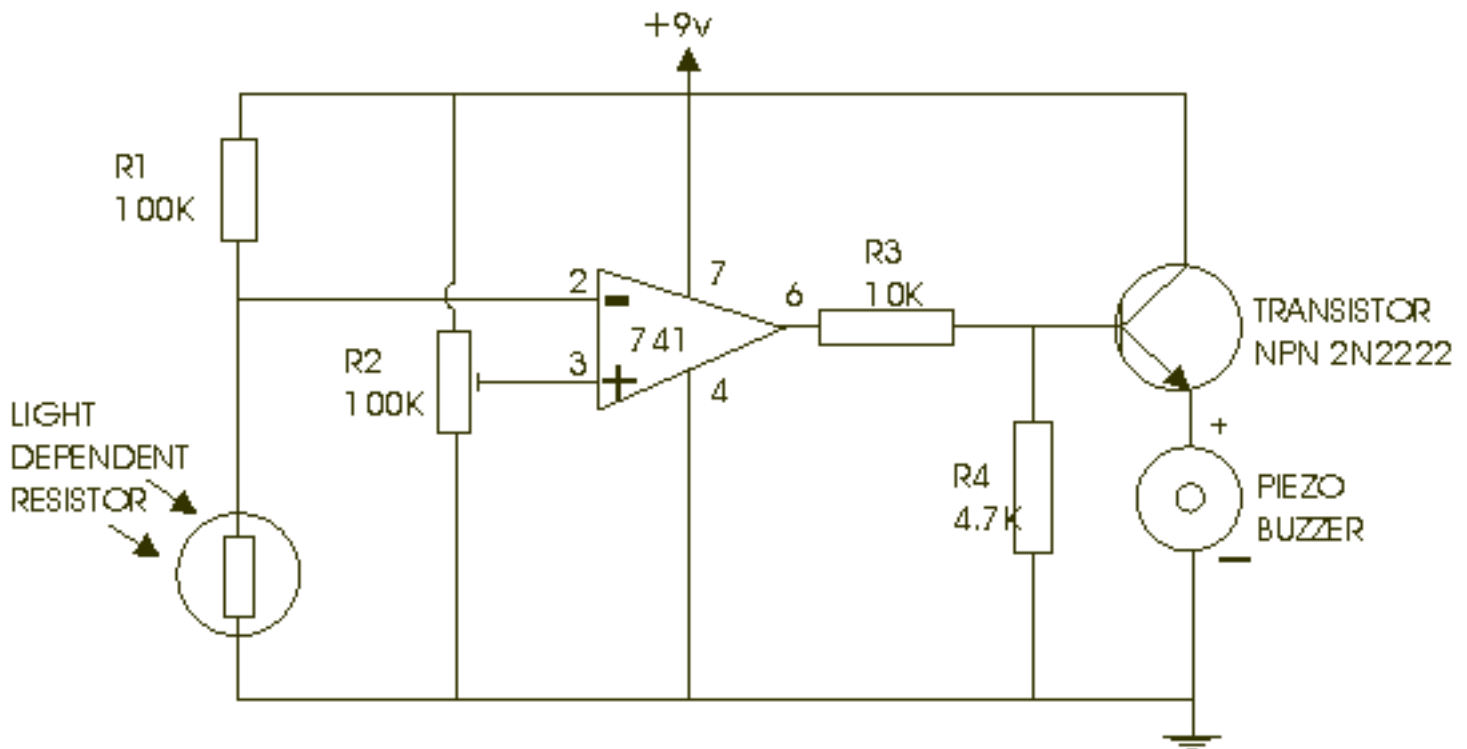

This is a dark activated circuit, the reverse of the circuit above. Do you notice the difference ?

If you look carefully you will notice that resistor 1 and the LDR have changed positions. Also, the inputs to the 741 are reversed.

Replace the LDR with a thermistor for a temperature circuit.

TECHNOLOGY/STUDENT.COM

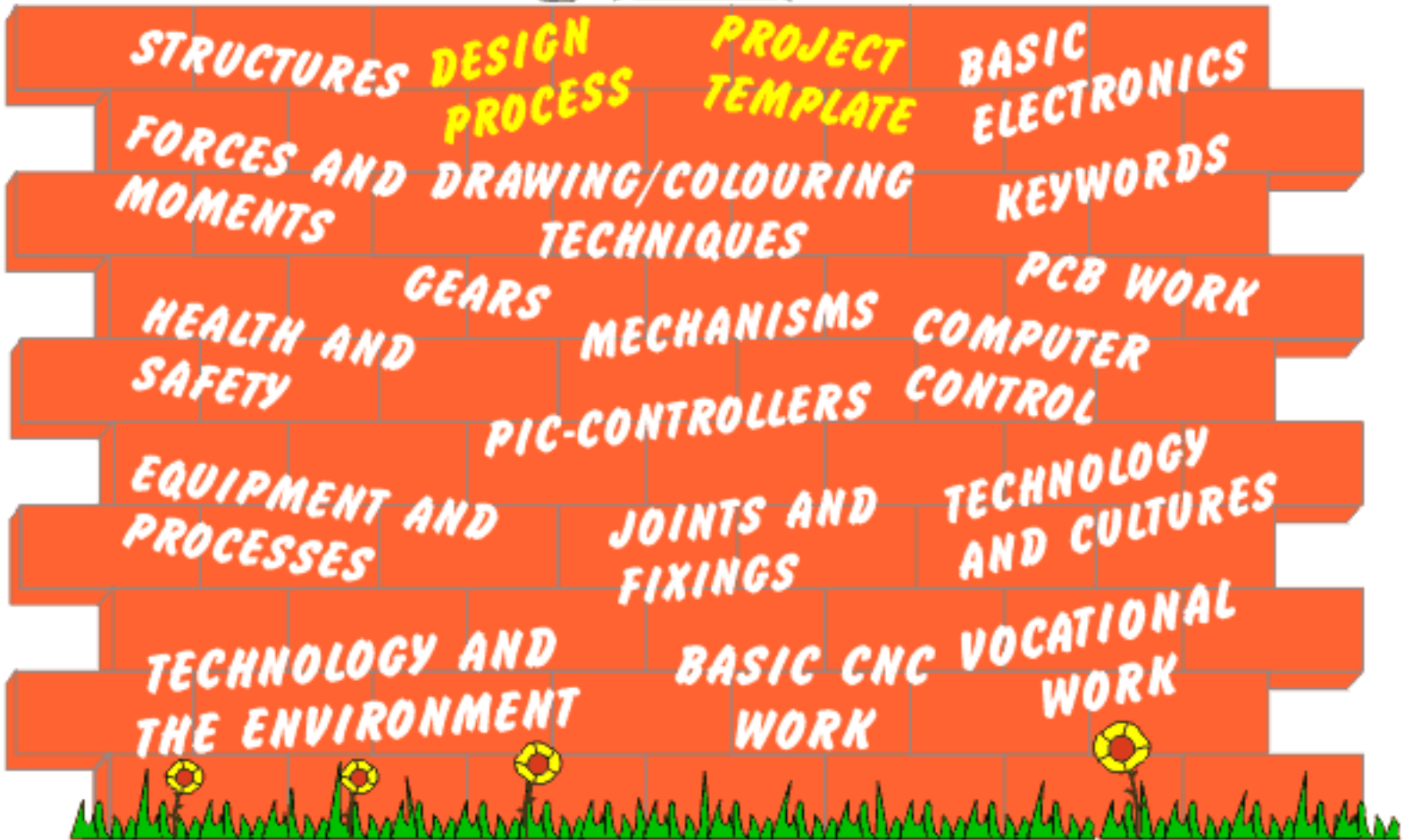

www.technologystudent.com is a detailed Design and Technology website for teachers, students and pupils. It is an improved and faster version of www.technologypupil.com.

V. Ryan © 2002-2003

TECHNOLOGYSTUDENT.COM - SITE SEARCH

Search for:

DESIGN AND TECHNOLOGY

This website contains numerous information sheets which will be helpful if you are studying or teaching DESIGN TECHNOLOGY. The information sheets cover a wide range and include, the design process, gear systems, electronics, cams, printed circuit boards, PIC microcontrollers / computer control, key words/phrases, structures, vocational work, technology and cultures, basic CNC work. They are intended to provide a valuable resource for teachers and pupils AND they are free.

[CONTACT THE AUTHOR ? - techteacher@teacher.com](mailto:techteacher@teacher.com)

[SCHEMES OF WORK](#)

[POLICY DOCUMENTS](#)

[QUALITY ASSURANCE](#)

[FREE MATERIALS](#)



[LINKS TO TECH SITES](#)

[LINKS TO SUPPLIERS](#)

[PARTNERSHIP](#)

[FREE MEMBERSHIP](#)

[JOIN W.A.T.T - CLICK ABOVE](#)

This work is protected by copyright law and international copyright treaties as well as other intellectual property laws and treaties.

Copyright law and other intellectual property laws in many countries protect the rights of the owner/author by granting to the owner/author a number of exclusive rights. Copying, changing, editing or publishing software/printouts without the permission of the owner is "copyright infringement," and the law imposes penalties on infringers.

These information sheets can be used by teachers and pupils. They can be printed and used for educational purposes but must not be edited in any form or placed on other Websites.

[COPYRIGHT AND DISCLAIMER](#)

[CLICK HERE FOR INDEX PAGE](#)

FORCES AND MOMENTS



V. Ryan © 2002

This aspect of the website is concerned with the different types of forces that can be applied to any structure. Moments of force and equilibrium are also discussed.

[1. Different Types of Forces](#)

[2. Struts and Ties](#)

[3. Structural Forces](#)

[4. More Forces in Action](#)

[5. Even More Forces In Action](#)

[6. Classes of Lever](#)

[7. Moments of Force and Example Questions](#) (Two Pages)

[CLICK HERE FOR INDEX PAGE](#)

FORCES

V. Ryan © 2002

There are different types of forces that act in different ways on structures such as bridges, chairs, buildings, in fact any structure. The main examples of forces are shown below. Study the diagram and text and then draw a diagram/pictogram to represent each of these forces.



A Static Load : A good example of this is a person seen on the left. He is holding a stack of books on his back but he is not moving. The force downwards is ***STATIC***.

A Dynamic Load : A good example of a dynamic load is the person on the right. He is carrying a weight of books but walking. The force is moving or ***DYNAMIC***.



STATIC LOAD (standing still)

DYNAMIC LOAD (moving)



Internal Resistance : The person in the diagram is sat on the mono-bicycle and the air filled tyre is under great pressure. The air pressure inside it pushes back against his/her weight.

Tension : The rope is in “tension” as the two people pull on it. This stretching puts the rope in ***tension***.

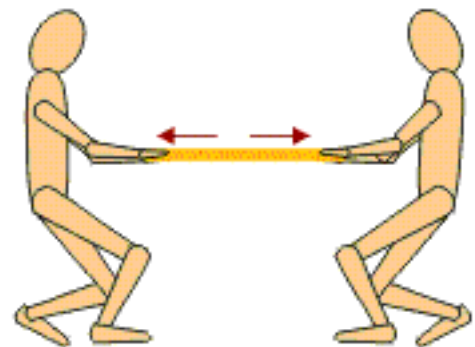

INTERNAL RESISTANCE

TENSION

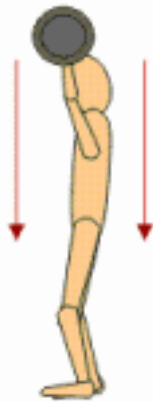

COMPRESSION

Compression : The weight lifter finds that his body is compressed by the weights he is holding above his head.

Shear Force : A good example of shear force is seen with a simple scissors. The two handles put force in different directions on the pin that holds the two parts together. The force applied to the pin is called *shear* force.



SHEAR FORCE

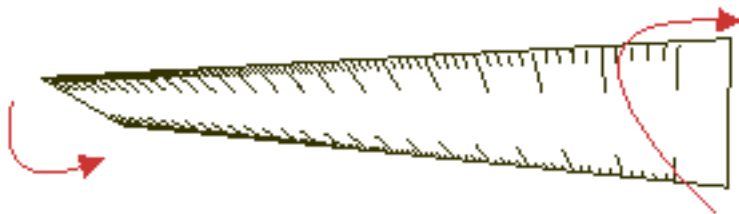

TORSION

Torsion : The plastic ruler is twisted between both hands. The ruler is said to be in a state of *torsion*.

[CLICK HERE FOR INDEX PAGE](#)

V. Ryan © 2001

STRUTS AND TIES

You must understand the meaning of 'struts, and 'ties' as these are always mentioned in examinations. All structures have forces acting on them. You should have an understanding of tensile, compressive and shear forces (see previous sheet). The part of the structure that has a tensile force acting on it is called a TIE and the part that has a compressive force acting on it is called a STRUT.

WALL

The beam is held in position by a steel rod. The weight of the beam is stretching the rod (tensile force).

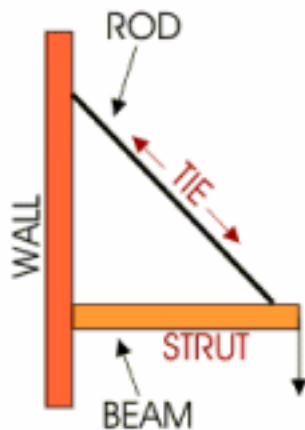

ROOF

The roof beams are under pressure from the weight of the tiles on the roof (compressive force). The floor beam is being stretched (tensile force).

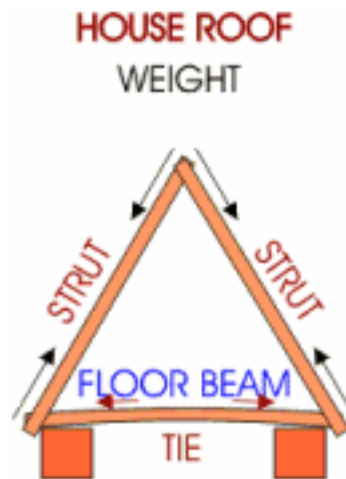

FLAGPOLE

The wires on either side of the flagpole are being stretched (tensile force).

Why is the pole under a compressive force ?



In the diagram opposite, forces act across the entire length of the beam (it bends because of the 'ton' weight). When a structure bends like this it is in tension as it is being stretched.

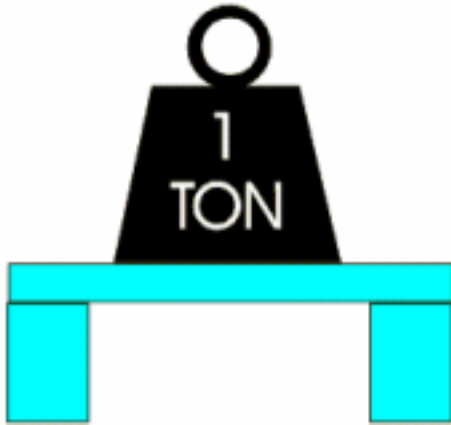

1. Draw an example of a structure and identify which part(s) are in tension and which are in compression.
2. Explain the difference between tension and compression.

[CLICK HERE FOR STRUCTURES INDEX](#)

[CLICK HERE FOR FORCES INDEX](#)

[CLICK HERE FOR INDEX PAGE](#)

STRUCTURAL FORCES

V. Ryan © 2002

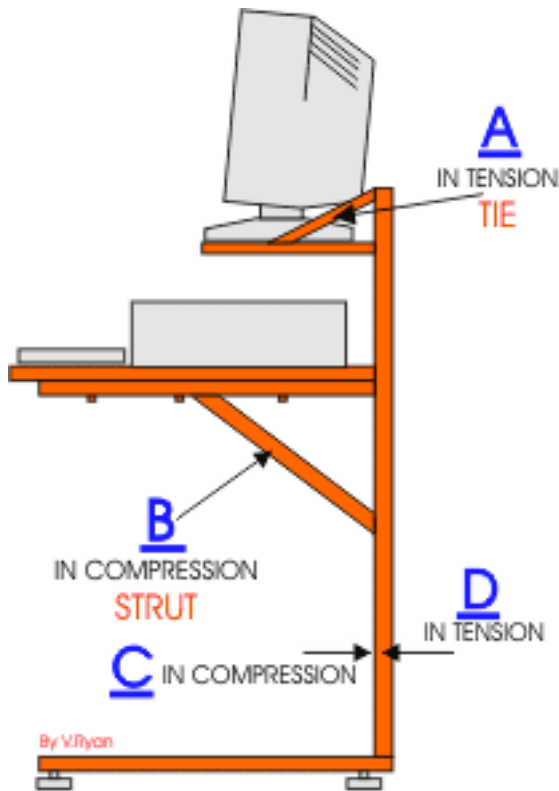

Study the diagram of a computer desk. Each member of the structure is under some type of force.

PART A: Is in tension because the weight of the computer is stretching it.

PART B: Is under compression because the weight of the computer unit and the members above that make up the desk, are pushing downwards and compressing it.

PART C and B: This is the same member but on the inside compression is taking place and on the outside it is being stretched (under tension).

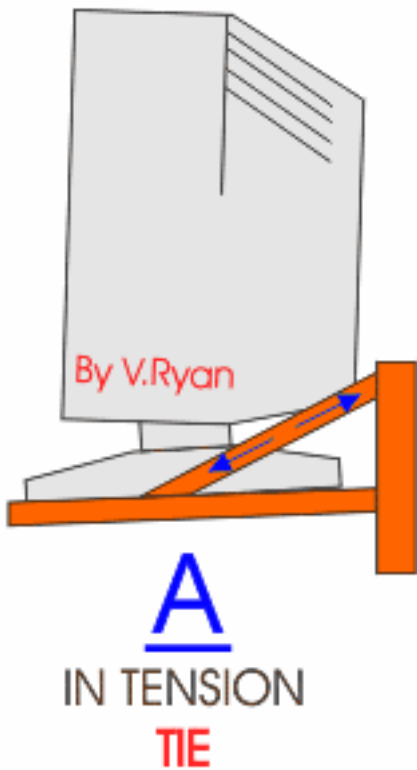

MONITOR WEIGHS DOWN
AND STRETCHES SUPPORT

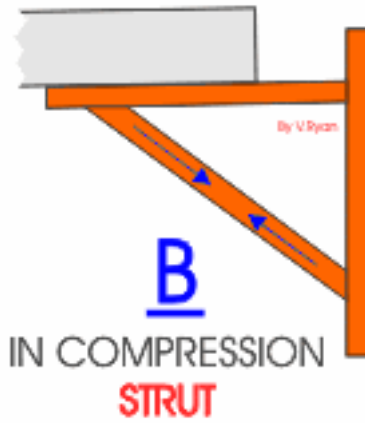

WEIGHT OF COMPUTER
UNIT COMPRESSES THE
SUPPORT BENEATH THE
SHELF

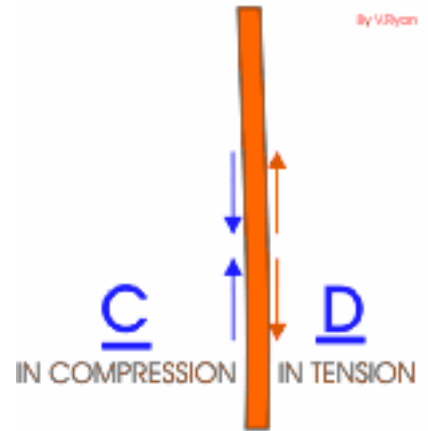

VERTICAL SUPPORT
BENDS INWARDS
BECAUSE OF WEIGHT OF
COMPUTER. SIDE 'D' IS
STRETCHED WHILST
'C' IS COMPRESSED

1. Draw a piece of furniture and label the struts and ties. With the aid of more detailed diagrams explain the forces acting on each of the important members.

[CLICK HERE FOR INDEX PAGE](#)

MORE FORCES IN ACTION

V. Ryan © 2002

The bridge below is a common type called a Box Girder Bridge. These are usually made of steel with all the members (parts) welded, bolted or held together with rivets. Usually they are manufactured in a factory and transported to the site and dropped into position by a large crane. The triangular shapes give the bridge immense strength and for short spans this type of bridge is ideal.

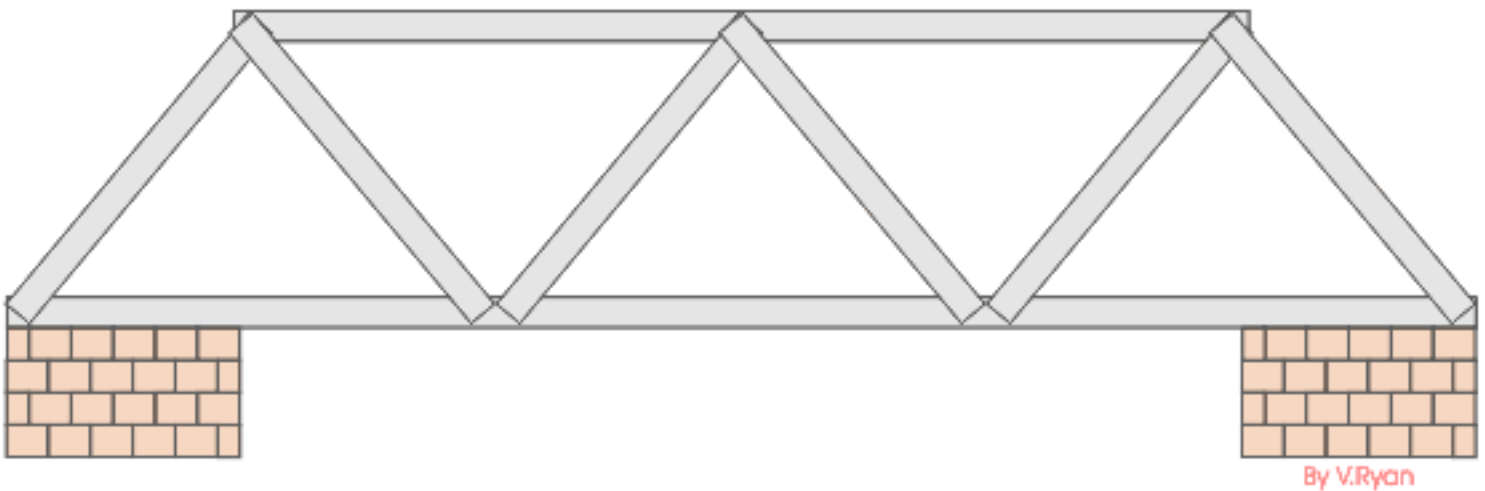

Triangulation distributes the weight of any vehicle or pedestrian crossing the bridge. The weight is distributed through all the members and so the bridge can cope with large weights. This type of bridge is favoured by the British Army. The Royal Engineers have transportable bridges like the one above that can be dismantled and transported anywhere in the world and reassembled. They are bolted together and are semi-permanent structures. [See work on the Mostar Bridge.](#)

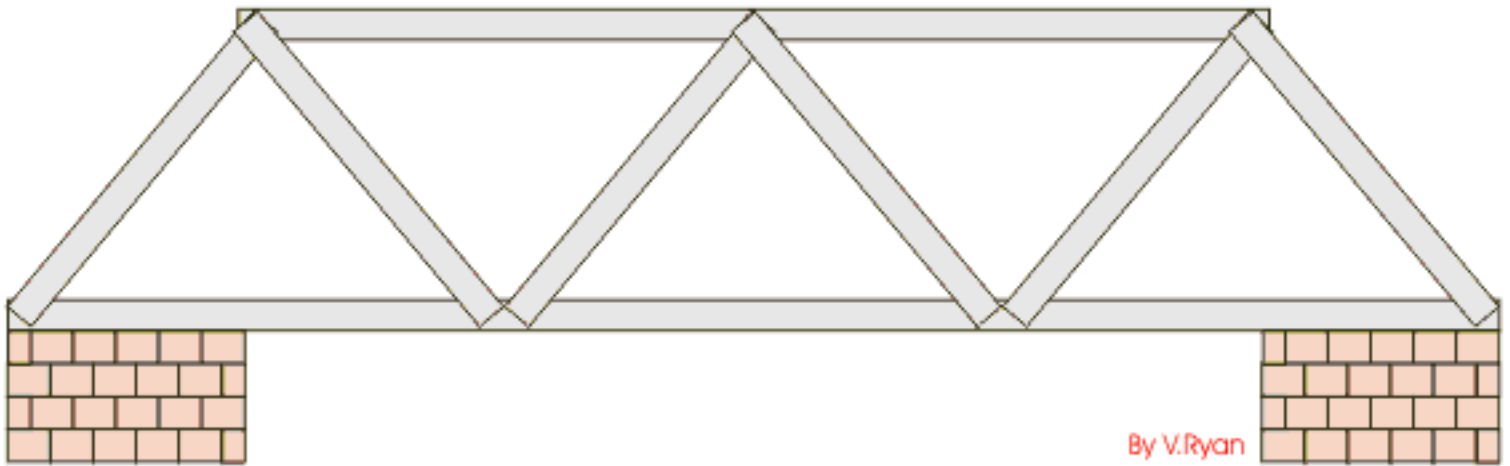

When a vehicle crosses the bridge each member experiences some type of force. The diagram shows that the member that the car rests on is under tensile force (in tension) as it stretches under the weight of the car. As the bridge bends, the top member is compress (under a compressive force).

1. Draw a diagram that shows the forces the supporting pieces (triangles) are under ? **HINT:** make a model from art straws and sellotape. This may help you see the forces in action as you add weights to the top.

[CLICK HERE FOR INDEX PAGE](#)

EVEN MORE FORCES IN ACTION

V. Ryan © 2002

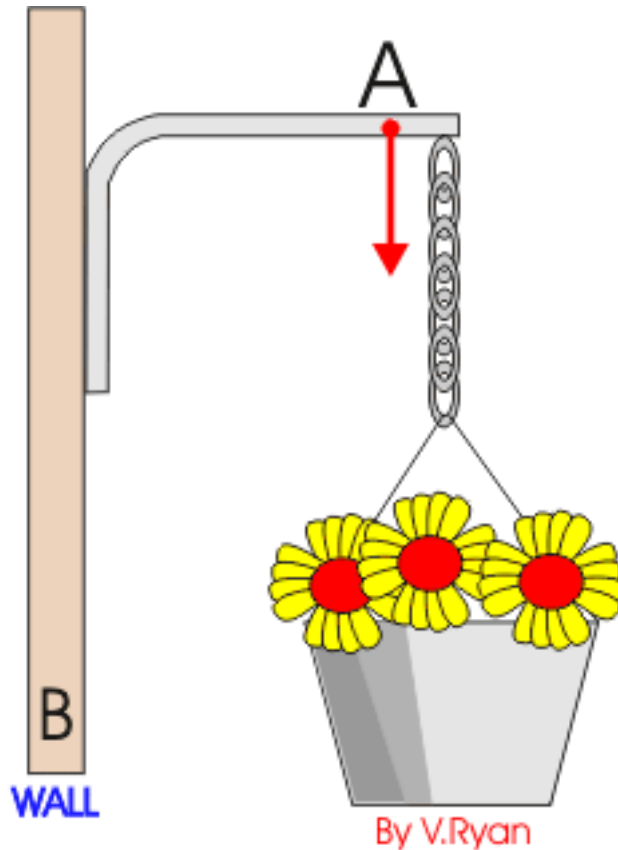

The bracket holding up the hanging basket is made of steel. It has been made by heating up the steel until 'red' hot and then bending it at 90 degrees.

1. What is the force exerting on the bracket at point 'A'?
2. What type of force is the chain under?
3. What type of force are the wires holding the plant pot under?
4. What force is acting on the wall at point 'B'?
5. As more weight is added to the plant pot the bracket begins to bend too much. How could the bracket be strengthened?
6. How could the bracket be fixed to the wall? Use diagrams to illustrate your answer.

ANSWERS TO QUESTIONS 1 TO 4

ANSWERS TO QUESTIONS 5 AND 6

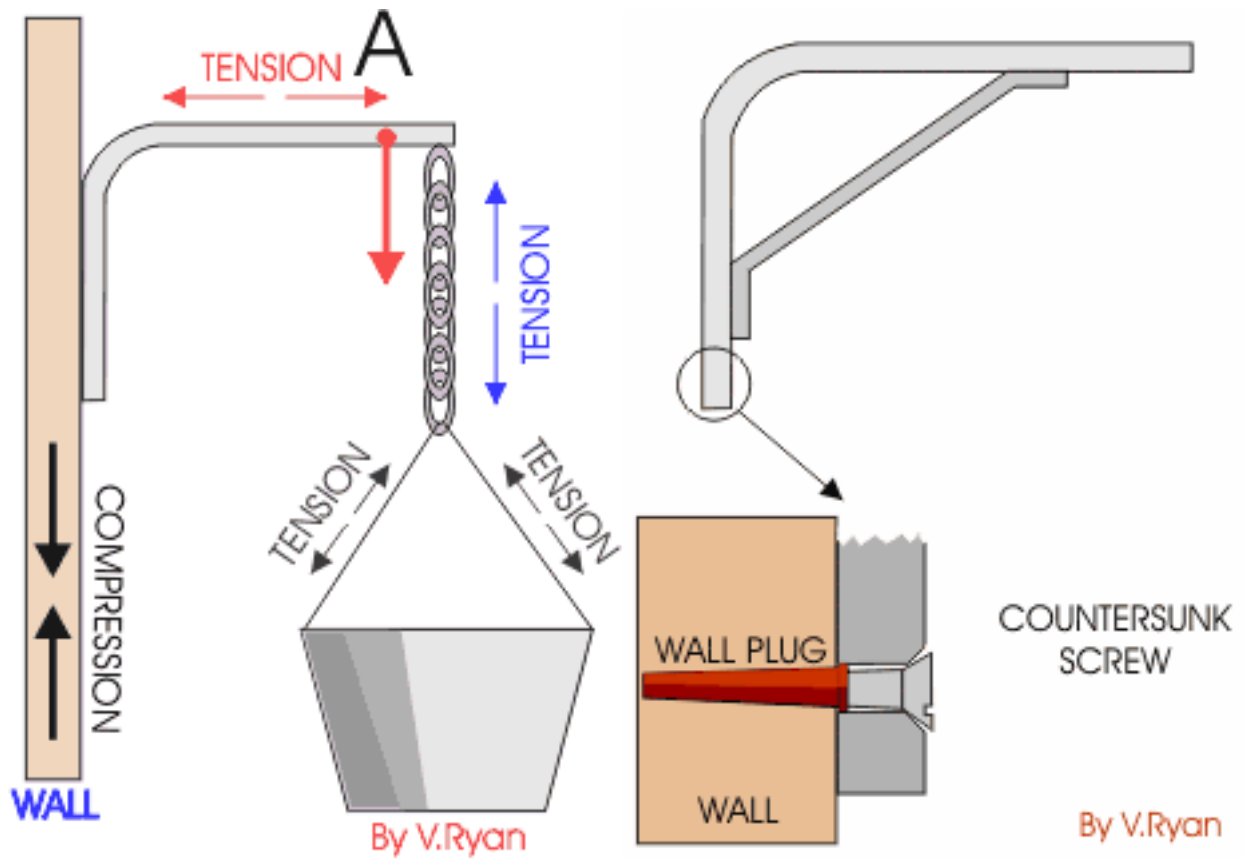

A steel bracket is added. Two holes are drilled, one at the top and bottom. Countersunk screws and wall plugs are used to fix the strengthened bracket to the wall. Two screws would be used.

[CLICK HERE FOR INDEX PAGE](#)

LEVERS

V. Ryan © 2002

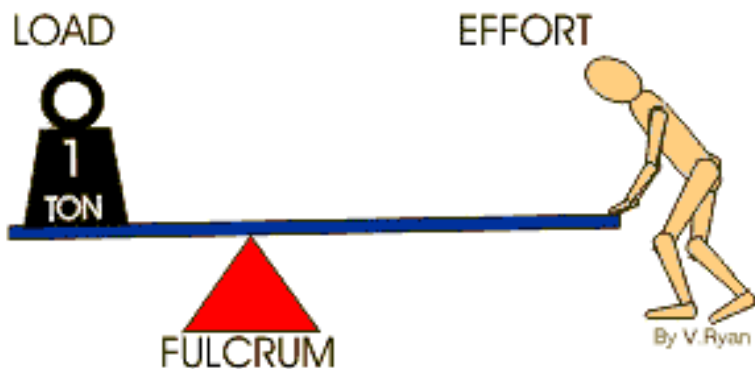

Levers are used to lift heavy weights with the least amount of effort. In the example opposite, the heavy weight on the left hand side is being lifted by the person because of the lever. The longer the 'rod' the easier it is to lift the weight. Under normal circumstances the person would not be able to lift the weight at all. The *fulcrum* is the place where the rod *pivots* (or rotates).

The *load* is the scientific name for the weight. The *effort* is quite simply the amount of effort used to push down on the rod in order to move the weight.

We use levers in every day life. Bicycle brakes work due to the fact that they are based on a lever. The diagram opposite shows the fulcrum and the effort.

Another good example of a lever is a simple door handle or a wheel barrow.

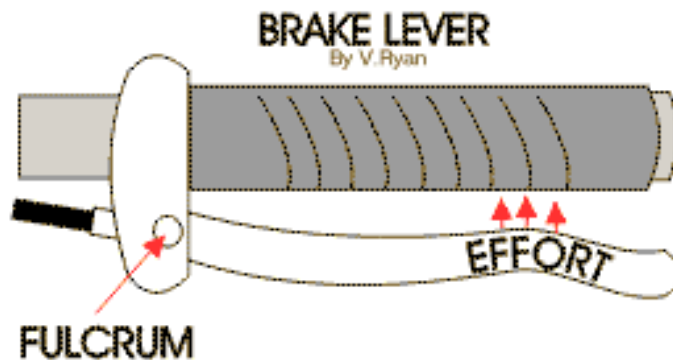

Draw three examples of levers that are used in everyday life.

THREE CLASSES OF LEVER

There are three classes of lever and each class has fulcrum, load and effort which together can move a heavy weight.

CLASS 1

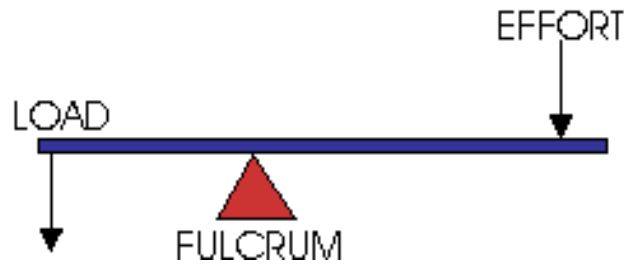

By V.Ryan



The workman uses a trolley to move the large packing case. The fulcrum is the wheel.

CLASS 2

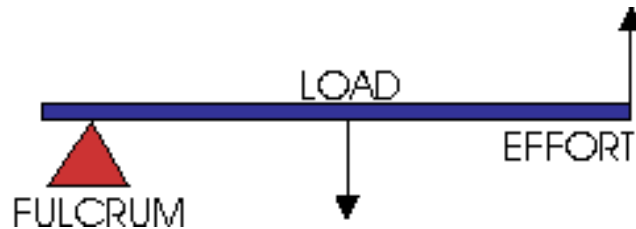

The gardener uses a wheel barrow to lift tools and garden waste. The load is in the centre of the barrow

CLASS 3

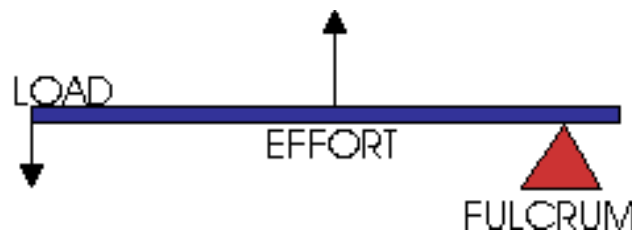

The fisherman catches the fish which becomes the load at the end of the lever.

Draw your own examples of the three classes of lever. Think in terms of examples that you have used at home, work or school.

[How did the Egyptians use levers to build the pyramids ?](#)

[CLICK HERE FOR INDEX PAGE](#)

FORCES

V. Ryan © 2002

The diagram below clearly shows a state of *equilibrium*. The cars on either side of the seesaw are exactly the same in weight and height, in fact they are the same model. As a result the seesaw stays level.

The centre of the seesaw is called the '*fulcrum*', seen here as a triangle and this is where the beam that the cars are on tilts backwards and forwards. However, because of the *state of equilibrium* they remain completely still.

The weight (the cars) is called the effort.

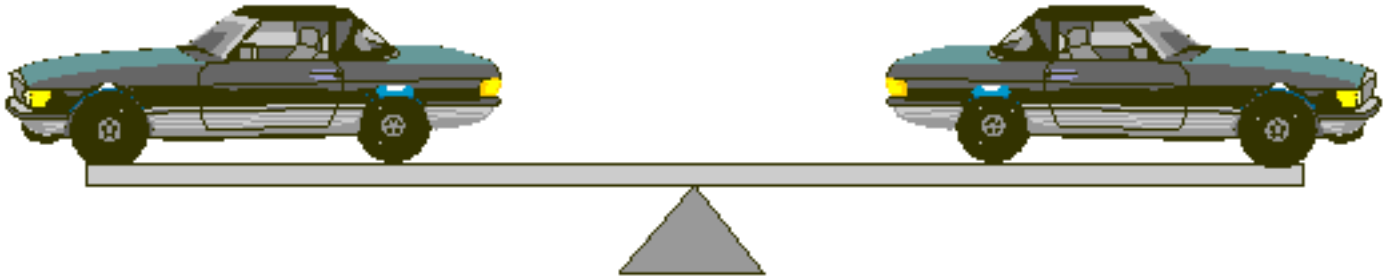

The cars are in a 'state of equilibrium' because the weight on either side is exactly the same

If an extra car is added to the right hand side (see diagram to right) then the seesaw will turn in a clockwise direction - called a **clockwise moment**.

Alternatively, if more cars are added to the left hand side the seesaw will turn in an anticlockwise direction - called an **anticlockwise moment**.

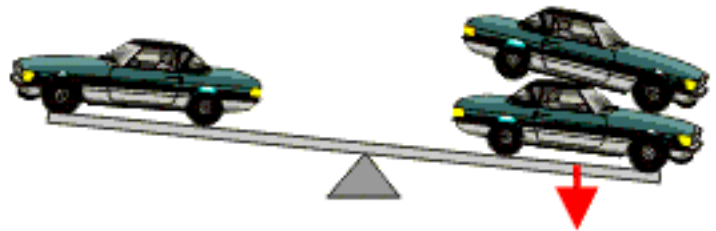

A clockwise moment as an extra car is added to the right side

If the seesaw is to be in equilibrium then the *clockwise moments* must be equal to the *anticlockwise moments*.

QUESTIONS

1. The diagram below shows a lever where an effort of 200 N balances a load of 600 N. The effort force is 6 metres from the fulcrum. The load force is two metres from the fulcrum.

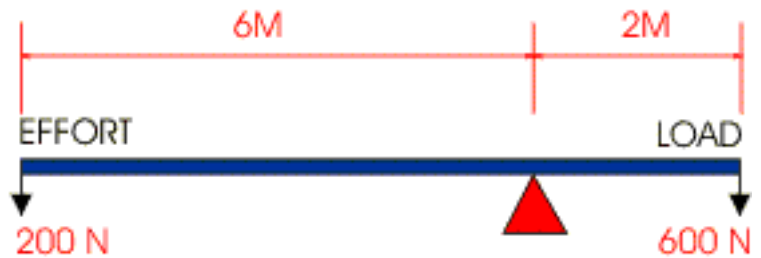

$$\text{Clockwise moment} = 600 \times 2 \text{ Nm}$$

$$\text{Anti-clockwise moment} = 200 \times 6 \text{ Nm}$$

In a state of equilibrium,

clockwise moments = anti-clockwise moments

$$600 \times 2 \text{ Nm} = 200 \times 6 \text{ Nm}$$

$$1200 = 1200$$

2. In the diagram below a crow-bar is used to move a 400n load. What effort is required to move the load?

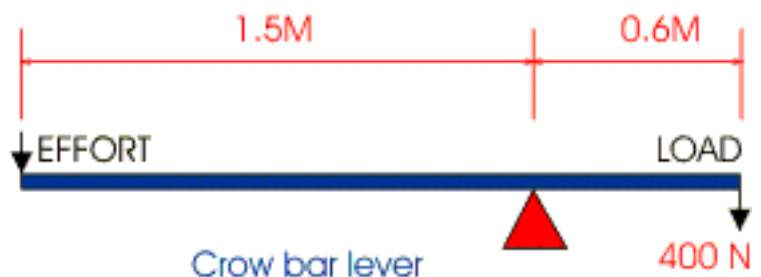

$$\text{Clockwise moments} = 400 \text{ N} \times 0.6 \text{ m}$$

$$\text{Anticlockwise moments} = \text{effort} \times 1.5\text{m}$$

In equilibrium;

clockwise moments = anti-clockwise moments

$$400 \times 0.6 = \text{effort} \times 1.5$$

$$\text{effort} = \underline{400 \times 0.6}$$

1.5

$$\text{effort} = \frac{240}{1.5}$$

1.5

$$= 160 \text{ N}$$

[CLICK HERE FOR MORE MOMENTS QUESTIONS](#)

[CLICK HERE FOR INDEX PAGE](#)

DRAWING/SHADING TECHNIQUES



V. Ryan © 2002

COLOURED PENCILS

- [1. Simple Shading Techniques - Flat Surfaces - \(Plastics and Metals\)](#)
- [2. Simple Shading Techniques - Curved Surfaces - \(Plastics and Metals\)](#)
- [3. Examples of Simple Shading Techniques \(Plastics\)](#)
- [4. Card Composite Drawings - \(Plastics\)](#)
- [5. Shading Natural Woods](#)
- [6. Drawing/Shading Exercise 1](#)
- [7. Drawing/Shading Exercise 2](#)

FELT PENS

- [8. More Advance Felt Pen and Coloured Pencil Work - \(Plastics and Metals\)](#)
- [9. Using Fine and Paint Brush Type Felt Pens - \(Plastics\)](#)
- [10. Examples - Felt Pens - \(Plastics\)](#)

SELECTING THE RIGHT COLOUR SCHEME

- [1. Primary, Secondary and Complementary Colours](#)

TWO and THREE DIMENSIONAL DRAWING

- [1. Exploded Views](#)
- [2. Single Point Perspective](#)
- [3. The Chair - Single Point Perspective](#)
- [4. The Table - Single Point Perspective](#)
- [5. Dressing Table - Single Point Perspective](#)
- [6. Interior Room - Single Point Perspective](#)
- [7. More Examples - Single Point Perspective](#)
- [8. Simple Examination Questions - Single Point Perspective](#)
- [9. Two Point Perspective\(1\)](#)
- [10. Two Point Perspective \(2\)](#)

- [11. House with Flat Roof - Two Point Perspective](#)
- [12. House with Conventional Roof - Two Point Perspective](#)
- [13. Two Point Perspective - More Examples](#)
- [14. Oblique Projection](#)
- [15. Cylinders Drawn in Oblique Projection](#)
- [16. Isometric Projection](#)
- [17. Isometric Circles and Cylinders](#)
- [18. Isometric Cube Exercise 1](#)
- [19. Isometric Cube Exercise 2](#)
- [20. Isometric Personal Stereo Exercise 2](#)
- [21. Printing in Isometric Exercise 3](#)
- [22. Isometric Diskette Exercise 4](#)
- [23. Isometric Mobile Phone Exercise 5](#)
- [24. First Angle Orthographic Projection](#)
- [25. Third Angle Orthographic Projection](#)
- [26. Dimensions \(Measurements\)](#)
- [27. Working Drawings](#)

ARCHITECTURAL DRAWINGS

- [1. Buildings - Plan Views/Architectural Drawings](#)
- [2. Location Maps and 'Zoom In' drawings](#)
- [3. Topological Maps](#)

PRINTING PROCESSES

- [1. The Letterpress \(1\)](#)
- [2. The Letterpress \(2\)](#)
- [3. The Rotary Letterpress](#)
- [4. Screen Printing](#)
- [5. Lithography](#)
- [6. The Photocopier](#)

GRAPHIC STYLES OF WRITING

- [1. Graphic Styles of Writing](#)
- [2. Examination Question - Writing Styles](#)

POP-UP CARD MECHANISMS

- [1. Pop-Up Card Rich Picture](#)

- [2. Pop-Up Card Problem and Brief](#)
- [3. Example Layout for Problem and Brief](#)
- [4. Pop-Up Card - Analysis](#)
- [5. Example Presentation - Pop-Up Card Analysis](#)
- [6. V-Fold Mechanisms and Internal Stands](#)
- [7. Rotary Card and Mouth Mechanisms](#)
- [8. Parallel Slide Mechanisms](#)

ASPECTS OF DESIGN

- [1. Logo Design](#)
- [2. Logo Exercise](#)
- [3. Logo Exam Question](#)

DEVELOPMENTS / NETS

- [1. What are Developments / Nets?](#)
- [2. Developments - Pyramids, Cones and Cuboids.](#)
- [3. Developments - Cylinders, Triangular Prisms, Point of Sale Question](#)
- [4. Development Exam Question](#)

[CLICK HERE FOR INDEX PAGE](#)

HOW A CAPACITOR CAN BE USED

V. Ryan © 2002

Using a capacitor in conjunction with a Computer Interface:



The capacitor is placed in parallel and when the switch is pressed it is charged. When the switch is released the capacitor discharges but as this happens it holds the relay closed for 3/4 seconds. This allows the computer enough time to detect the closed relay and then it turns on a motor.

Using a capacitor as part of a 555 Timer Circuit:

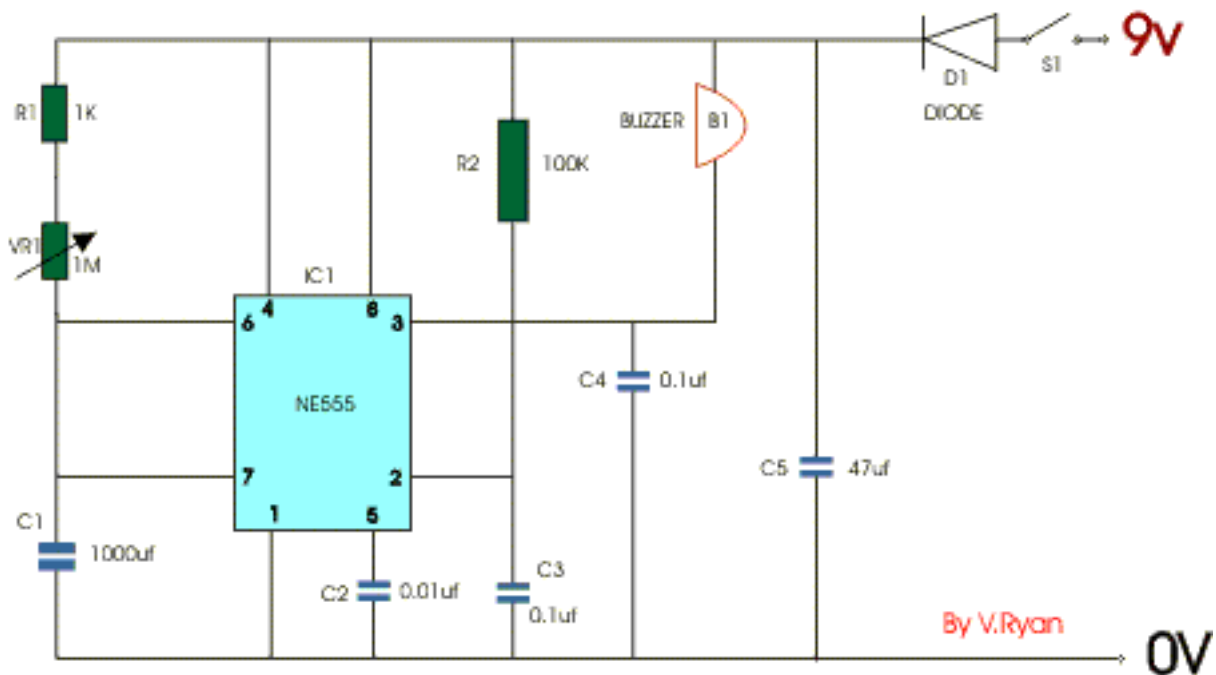

The 555 circuit shown above is more sophisticated than the circuit above and is composed of several components including the integrated circuit (NE555). When switched on the buzzer sounds for a certain amount of time.

Some of the components are resistors and capacitors. It is often the combination of resistors and capacitors that control the time delay - in this case the length the buzzer sounds for.

If the capacitor C1 is changed for a higher value capacitor then the buzzer sounds for a longer period of time. The variable resistor VR1 can also determine the length of time.

What will happen if the value of the capacitor is reduced ?

[CLICK HERE TO GO BACK TO CAPACITOR INTRODUCTION](#)

[CLICK HERE FOR INDEX PAGE](#)

RESISTORS IN PARALLEL - FURTHER QUESTIONS

V. Ryan © 2002

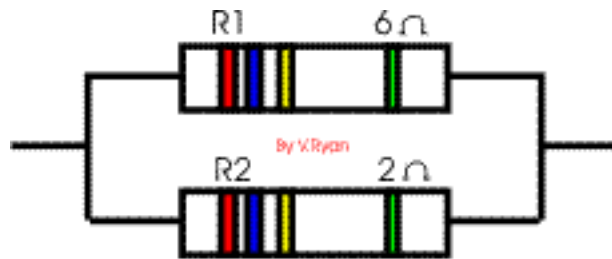

1. Calculate the total resistance for the two resistors in parallel

MULTIPLICATION

$$\frac{R1 \times R2}{R1 + R2} = \frac{6 \times 2}{6 + 2} = \frac{12}{8} = 1.5\Omega$$



2. Calculate the total resistance for the two resistors in parallel

$$\frac{R1 \times R2}{R1 + R2} = \frac{6 \times 3}{6 + 3} = \frac{18}{9} = 2\Omega$$

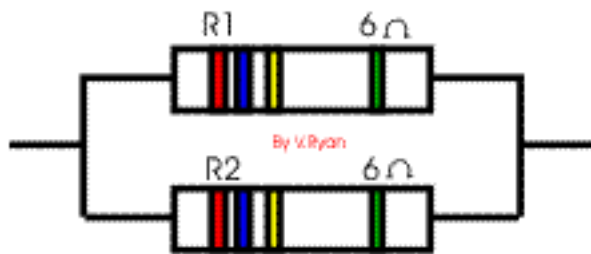

3. Calculate the total resistance for the two resistors in parallel

$$\frac{R1 \times R2}{R1 + R2} = \frac{6 \times 6}{6 + 6} = \frac{36}{12} = 3 \Omega$$

[QUESTIONS ABOUT THREE RESISTORS IN PARALLEL - CLICK HERE](#)

[CLICK HERE FOR INDEX PAGE](#)

RESISTORS IN PARALLEL - QUESTIONS

V. Ryan © 2002

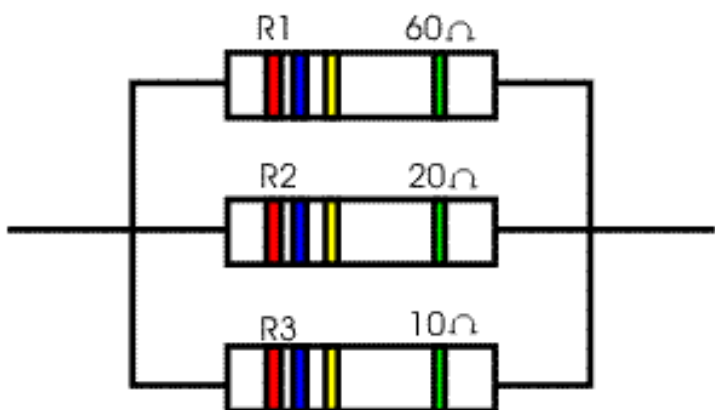

1. Calculate the total resistance for the three resistors in parallel

The usual formula is seen opposite although it is easier to break down the calculation into two separate ones. These are similar to calculations you have attempted earlier.

To make the calculation easier calculate the total of the first two resistors.

$$\frac{1}{R_{\text{(total)}}} = \frac{1}{R1} + \frac{1}{R2} + \frac{1}{R3}$$

$$\frac{1}{R_{\text{(total)}}} = \frac{1}{R1} + \frac{1}{R2}$$

MULTIPLICATION

$$\Rightarrow \frac{R1 \times R2}{R1 + R2} = \frac{60 \times 20}{60 + 20} = \frac{1200}{80}$$

$$\Rightarrow 15\Omega R_{\text{(total)}}$$

Then, take the total of the first two resistors and perform the same calculation with the third resistor. This gives the overall total resistance.

$$\frac{R_{\text{(total)}} \times R3}{R_{\text{(total)}} \times R3} = \frac{15 \times 10}{15 + 10} = \frac{150}{25} = 6\Omega$$

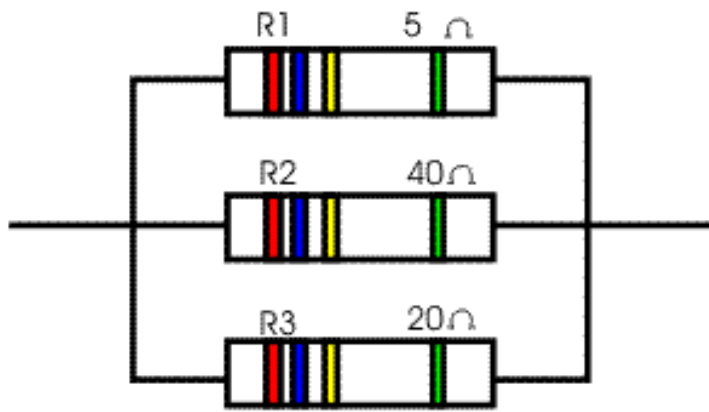

2. Calculate the total resistance for the three resistors in parallel

First calculate the total resistance of the first two resistors.

$$\frac{1}{R_{(total)}} = \frac{1}{R1} + \frac{1}{R2}$$

$$\Rightarrow \frac{R1 \times R2}{R1 + R2} = \frac{5 \times 40}{5 + 40} = \frac{200}{45}$$

$$\Rightarrow 4.4 \Omega R_{(total)}$$

Then, take the total of the first two resistors and perform the same calculation with the third resistor. This gives the overall total resistance.

$$\frac{R_{(total)} \times R3}{R_{(total)} + R3} = \frac{4.4 \times 20}{4.4 + 20} = \frac{88}{24.4} = 3.6 \Omega$$

[CLICK HERE FOR INDEX PAGE](#)

PRACTICAL EXAMPLES OF THE USE OF RELAYS

V. Ryan © 2002

Below are some examples that show how relays can be used as part of a practical circuit. As stated in the first information sheet, the relay is normally used to switch 'on' another circuit.

RAIN ACTIVATED ALARM

This circuit is simple in its operation, if it rains the relay is 'energised' (switched). This could be part of a rain detection system. The rain falls onto a small sensor which allows current to flow from positive to negative. Current also flows into the base of the transistors and the relay is energised. In turn, a second circuit is switched on and the piezo buzzer sounds. This circuit could be used to warn of rain so that the washing could be collected in before it gets too wet.

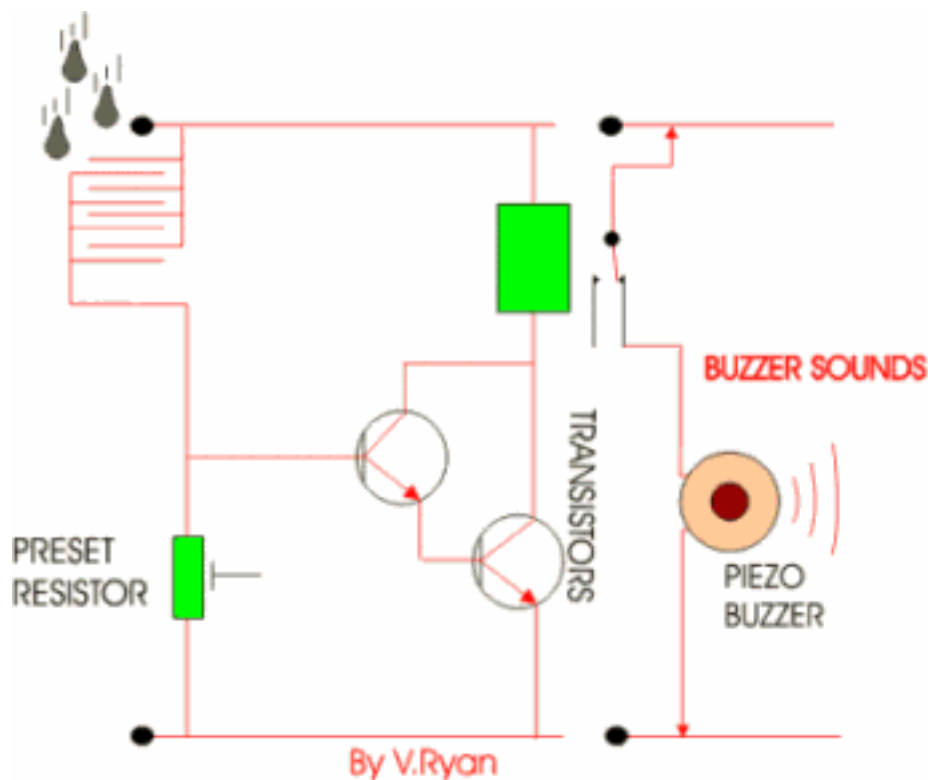

THE ZN 1034 PRECISION TIMER AND RELAY

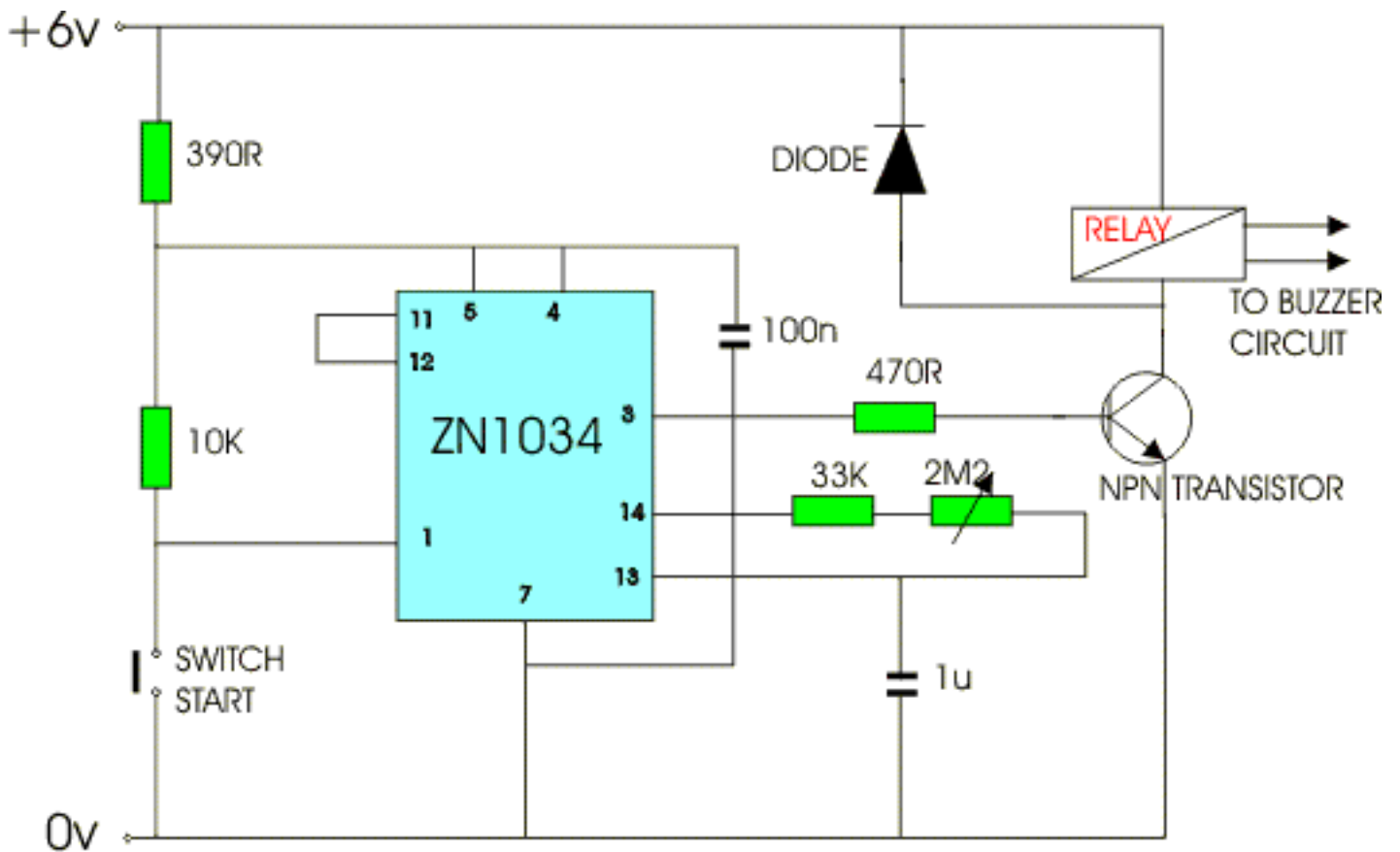

The *ZN 1034* integrated circuit is a precision timer. It is an extremely useful chip and often is used in conjunction with a relay. In this circuit when the switch is pressed the relay is 'energised' for a period of between two and one hundred minutes, depending on how the variable resistor has been set. This means the buzzer sounds for that amount of time.

It is a simple task to slightly alter the circuit so that when the switch is pressed the buzzer does not sound until after the set time - a delay has been introduced.

[CLICK HERE FOR INDEX PAGE](#)

V. Ryan © 2001

CIRCUIT RESEARCH

(Two Pages)

Circuit research is very important especially if you are studying Electronics or Systems and Control. You must show that you have a clear understanding of INPUT, PROCESS, OUTPUT. Therefore, every time you draw a circuit clearly break in down into these three aspects. Examples are shown below:

THE 555 TIMER

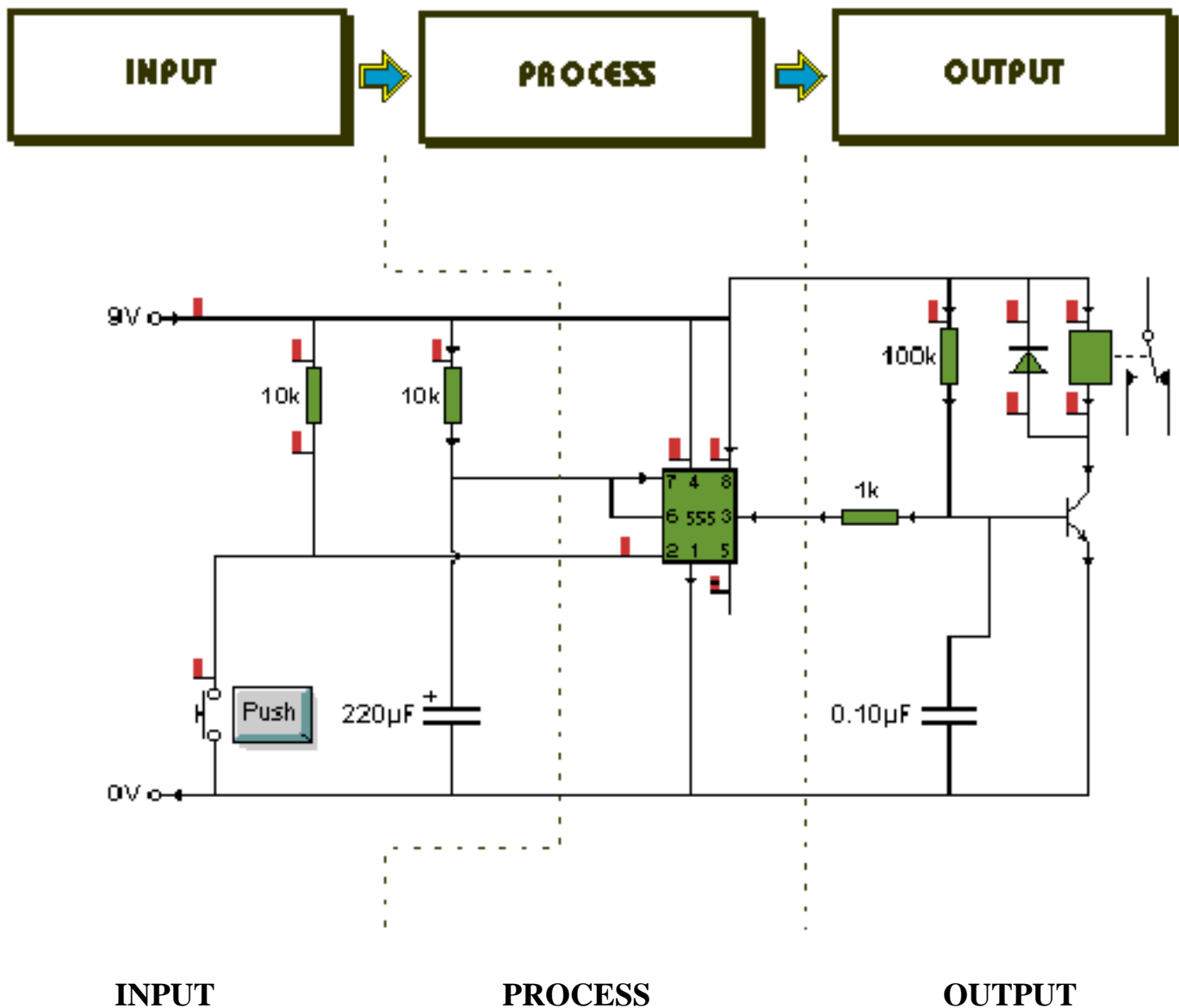

THE PUSH SWITCH STARTS THE CIRCUIT BY ALLOWING CURRENT TO FLOW INTO PIN 2 OF THE 555 TIMER. THIS INPUT WOULD BE SUITABLE FOR MY ALARM AS IT WOULD BE EASY TO PRESS.

THE 555 IS A VERSATILE IC AND CAN BE SET UP TO ALLOW A SMALL TIME DELAY OF A FEW SECONDS OR THE DELAY CAN BE EXTENDED BY INCREASING THE VALUE OF THE CAPACITOR. THE DELAY COULD BE SET FOR UP TO TWENTY MINUTES.

AS THE 555 COMPLETES ITS TIMING CYCLE IT OUTPUTS A CURRENT AT PIN 3. THIS TRIGGERS THE TRANSISTOR WHICH IN TURN ENERGISES THE RELAY. THIS COULD BE A SOLUTION FOR MY ALARM AS THE RELAY COULD ACTIVATE A SECOND CIRCUIT

THE 741 OPERATIONAL AMPLIFIER

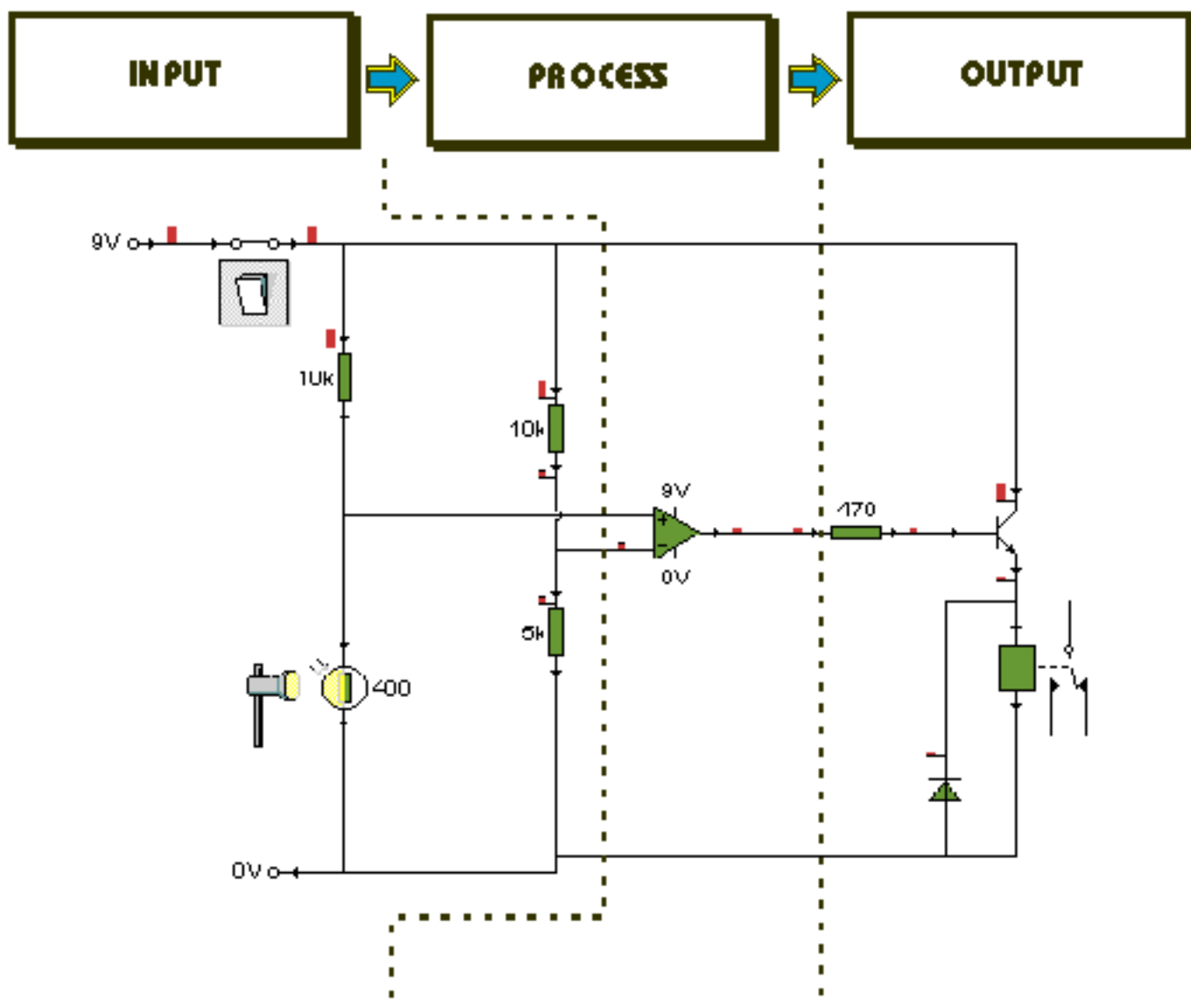

INPUT

THE LIGHT/DARK
SENSOR COULD BE
USED TO TRIGGER MY
ALARM. AS THE A
POTENTIAL THIEF GETS
IN THE WAY OF THE
SENSOR THE CURRENT
INTO THE Op Amp
CHANGES.

PROCESS

THE Op Amp DETECTS THIS
CHANGE IN CURRENT AND
AS A RESULT THERE IS AN
OUTPUT OF CURRENT
FROM PIN 6

OUTPUT

THE CURRENT FROM PIN 6
TRIGGERS THE
TRANSISTOR AND
ENERGISES THE RELAY. A
SECOND CIRCUIT COULD
BE ADDED. THIS COULD BE
A BUZZER/SOUND CIRCUIT
OR FLASHING LED
CIRCUIT.

[CLICK HERE FOR SECOND CIRCUIT RESEARCH PAGE](#)